



N150PSL800P HIGH FLOW DIESEL NOZZLE



MINING | QUARRY | CONSTRUCTION



Only Trust your "FLUID EQUIPMENT SPECIALISTS"

WWW.SILVERIENG.COM | SALES@SILVERIENG.COM | 1300 716 413 | WHATSAPP +61 458 047 075



N150PSL800P

HIGH FLOW

DIESEL NOZZLE



N150PSL800P (WITH PLUG)

Proven reliability in the harshest environments.

Engineered with a durable all-metal construction and thick-wall main housing, this nozzle is purpose-built for demanding, heavy-duty operations. Its robust design ensures maximum longevity and consistent performance under extreme conditions.

The advanced latching mechanism incorporates twelve stainless steel ball bearings, delivering a secure, positive connection every time while enhancing operational safety and efficiency.

ACCESSORIES:

- P150 PLUG & LANYARD
- P150S STEEL PLUG & LANYARD
- S200 2" SWIVEL
- R150S DIESEL RECEIVER
- R150SC-A DIESEL RECEIVER WITH CAP or
- R800CVC DIESEL CHECK VALVE RECEIVER WITH CAP
- V150H HIGH FLOW VENT



Only Trust your "FLUID EQUIPMENT SPECIALISTS"

WWW.SILVERIENG.COM | SALES@SILVERIENG.COM | 1300 716 413 | WHATSAPP +61 458 047 075



N150PSL800P

HIGH FLOW

DIESEL NOZZLE



MAX OPERATING: 5.17 BAR, 75 PSI
 PRESSURE MAX FLOW: 800 LPM, 200 GPM RATE
 MIN FLOW RATE: 95 LPM, 25 GPM
 FUEL INLET THREADS: 2" NPT
 WEIGHT: 3.1 KG

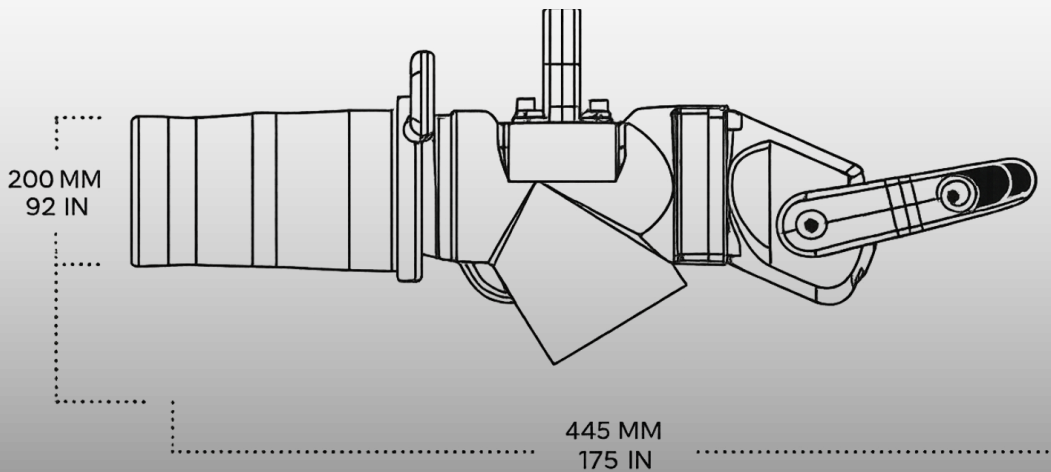

Only Trust your "FLUID EQUIPMENT SPECIALISTS"

WWW.SILVERIENG.COM | SALES@SILVERIENG.COM | 1300 716 413 | WHATSAPP +61 458 047 075