



N150AT ATLAS DIESEL NOZZLE



Mining | Quarry | Construction



"FLUID EQUIPMENT SPECIALISTS"

The compact refuelling nozzle is rated for flow rates up to **150 GPM (567 LPM)**. It features a **durable stainless steel nose** on the actuating ring and can be configured with either an **aluminium front end** for the lightest possible nozzle weight, or a **stainless steel front end** for increased durability.

The **N150AT** incorporates **twelve stainless steel ball bearings**, ensuring secure and reliable latching to the receiver.

Key Features:

- Compact, lightweight design
- Stainless steel ball bearing latching mechanism
- Powder-coated body for improved grip and durability
- Field-replaceable backend cartridge for easy maintenance
- Stainless steel actuating ring nose
- Available with an all-stainless steel front end
- Available with dual wiper seals for enhanced sealing performance

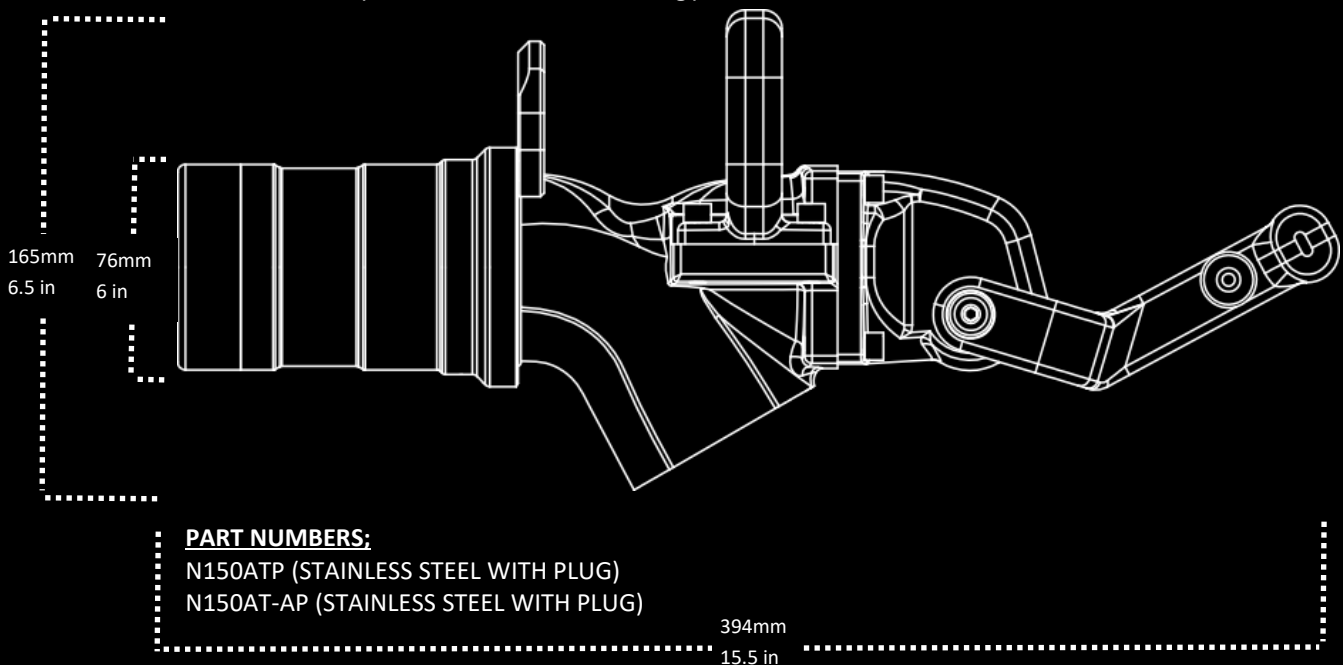

Technical Specifications



Parameter	Configuration	Metric	Imperial
Max Operating Pressure		8.6 bar	125 psi
Max Flow Rate		567 LPM	150 GPM
Min Flow Rate		95 LPM	25 GPM
Fuel Inlet Threads		38.1 mm	1-1/2" NPT
Weight	Aluminium Front End	2.6 kg	5.6 lbs
	Stainless Steel Front End	2.89 kg	6.38 lbs
Latching Mechanism		Stainless Steel Ball Bearings	—