



v2.1

sales@silverieng.com
www.silverieng.com
1300 766 413

FAST FILL SYSTEMS

PLA80-HVSC Owners Manual



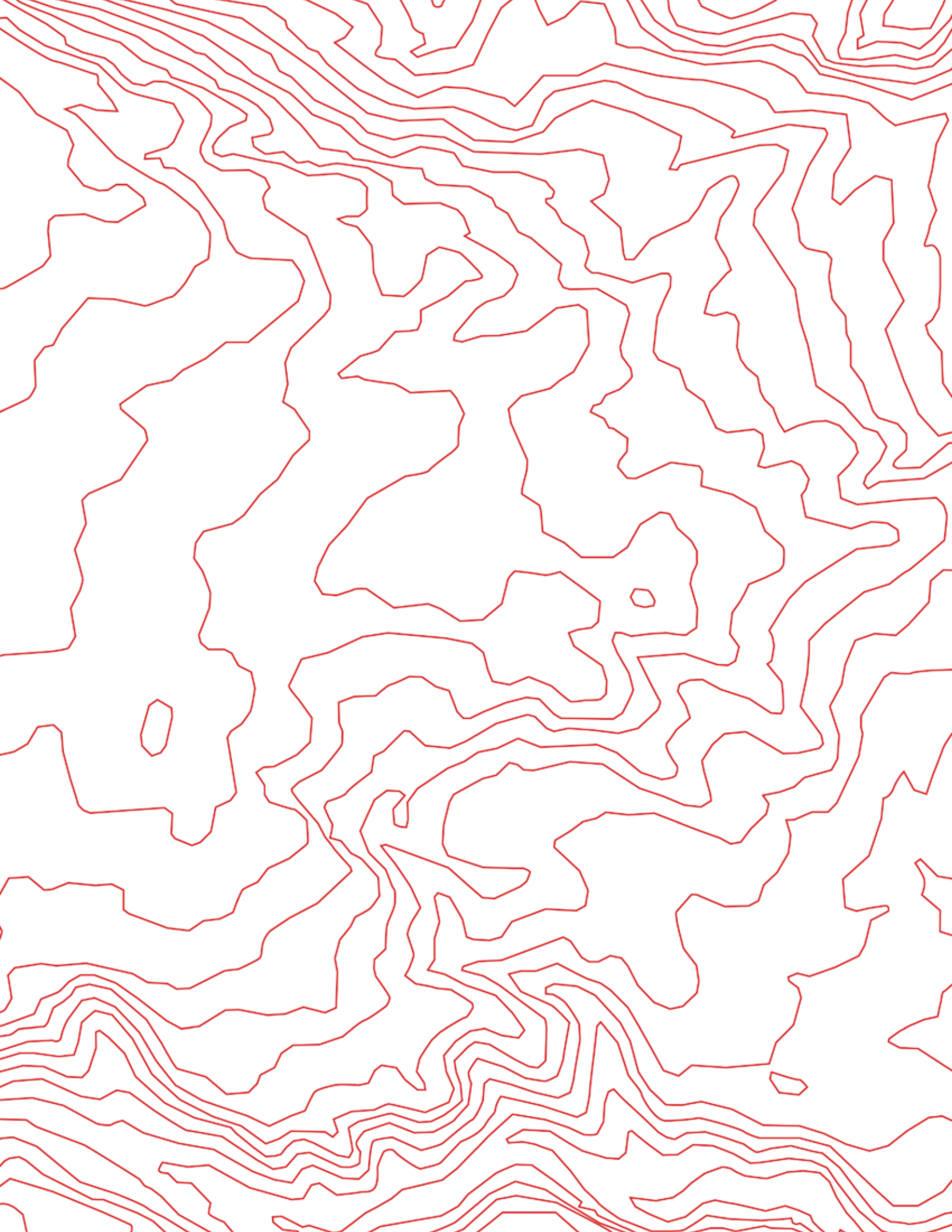



FAST FILL SYSTEMS

// 1195 Spring Creek Place Springville, UT 84663

// 801. 491.3600

// orders@fastfillsystems.com

// www.fastfillsystems.com

SMALL TANK PRESSURELESS



FAST FILL SYSTEMS

PLA80

The PLA80 brings pressureless fluid transfer to applications where it was once unavailable. This all-in-one, drop in system fits standard 2" NPT inlets and enables individual tank fill and shut-off for single or multi-tank configurations. Once the fuel level reaches 90-95% capacity, each tank will automatically shut-off, eliminating under/over filling. The auto shut-off feature works with all standard fuel nozzles (up to 80 GPM). With filtered venting and a dry break fill point, contamination is dramatically decreased. This product is ideal for agriculture, small construction, oil extraction, and mass transit equipment, because of its compact design and ease of installation. **This system can transfer ALL fluids; including Crankcase, Coolant, Hydraulic, and Transmission.**

- Fills and vents in a single 2" NPT port
- Completely pressureless operation
- Independent tank shut-off when used in daisy chain configurations
- Low profile filter vent or remote mount
- Adjustable shutoff level
- 1-1/4" FNPT fuel inlet threads
- 1" FNPT vent port threads
- Standard weight: 3.92 lbs | 1.78 kg

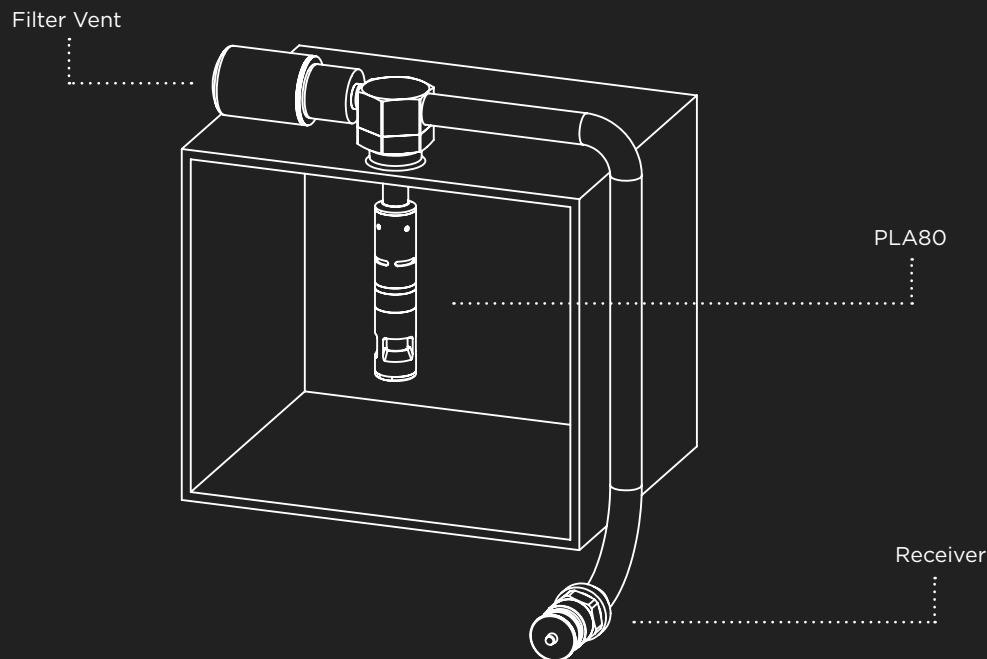

*Max High Flow Rate	**Max Standard Flow Rate	Min Flow Rate	Max Operating Temperature	Min Operating Temperature
302 LPM 80 GPM	151 LPM 40 GPM	23.6 LPM 5 GPM	150° F 65.6° C	-30° F -34.4° C

* High Flow Nozzles include N150PSL800, N1000PSL
 ** Standard Nozzles include N150PB, N150PSL, N150C

PART SPECIFICATIONS AND RECOMMENDATIONS

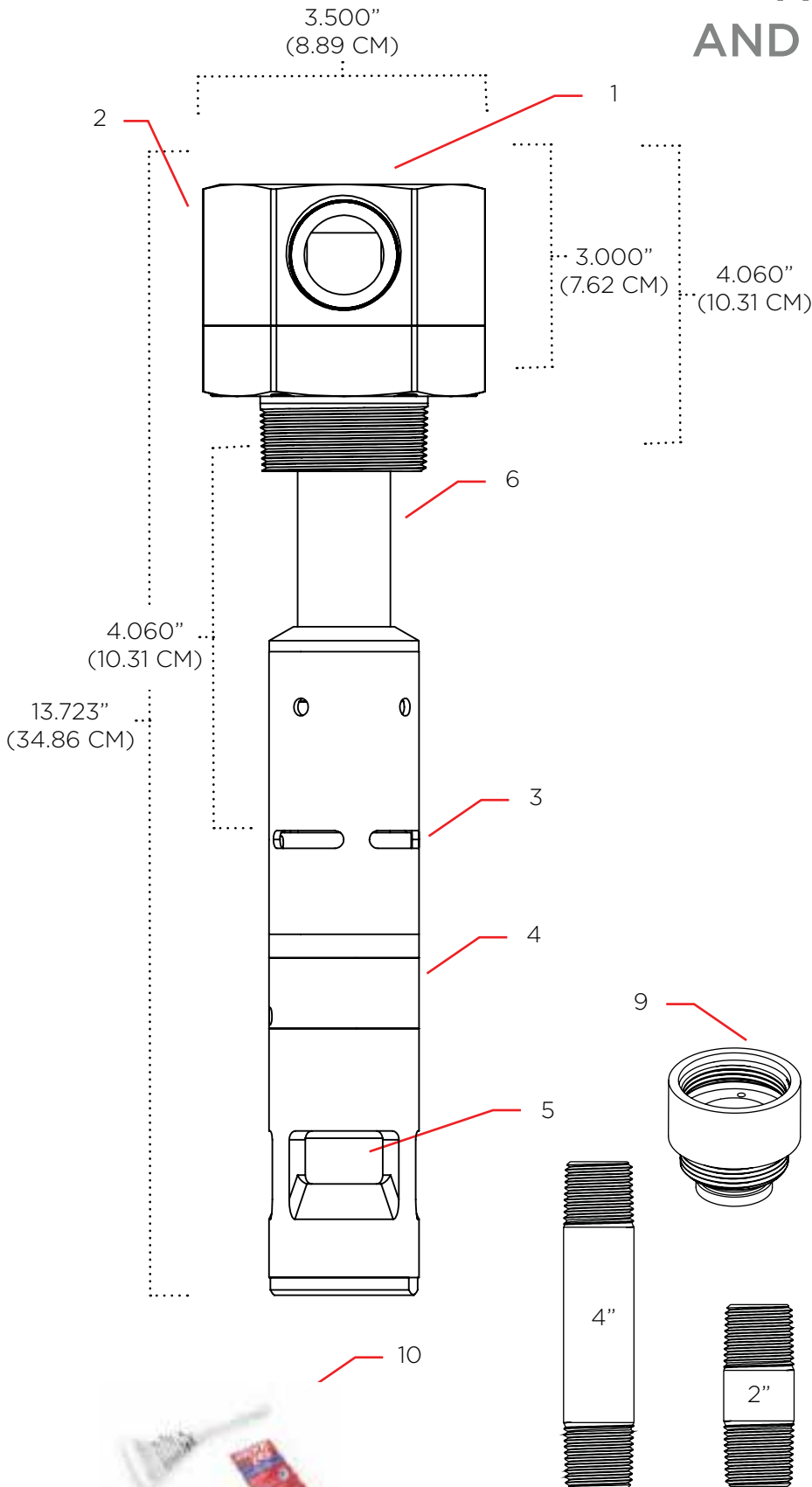

PLA80

Single Inlet Pressureless Unit

1. 1-1/4" NPT Threaded Inlet
2. 1" NPT Thread Vent Port
3. Level Control Float Chamber
4. 1" Spacers (add extras here)
5. Hydraulic-Locking Shutoff Valve
6. 3" Drop down tube (PL80-Mz-1b)

Special Instructions

- Adjust the Shut-off Level by changing the drop down tube length (Standard 3" Tube Shutoff Level is 5.461" below top of 2" NPT threads); Shutoff level must allow for 7-10% ullage (by volume); Refer to our ullage calculator found on our website: www.fastfillsystems.com/downloads.html

- Check all joints and fittings to make sure they are secure; Apply thin bead of Loctite #243 to secure any spacers or loose fittings

- Use Pipe Dope or Teflon tape on all threads - 2" NPT, 1-1/4" NPT, and 1" NPT

- Keep the level control float chamber and shutoff valve (areas 3 and 4) clean from dirt and debris during installation

- Check that the PLA80 is properly secured to the fuel tank

Accessories

For use with PLA80

7. 2" Drop down tube
8. 4" Drop down tube
9. 1" Spacer **Sold Separately**
10. Loctite #243

FAST FILL SYSTEMS

PART SPECIFICATIONS AND RECOMMENDATIONS (CONT.)

Auxiliary Views and Component Identifications

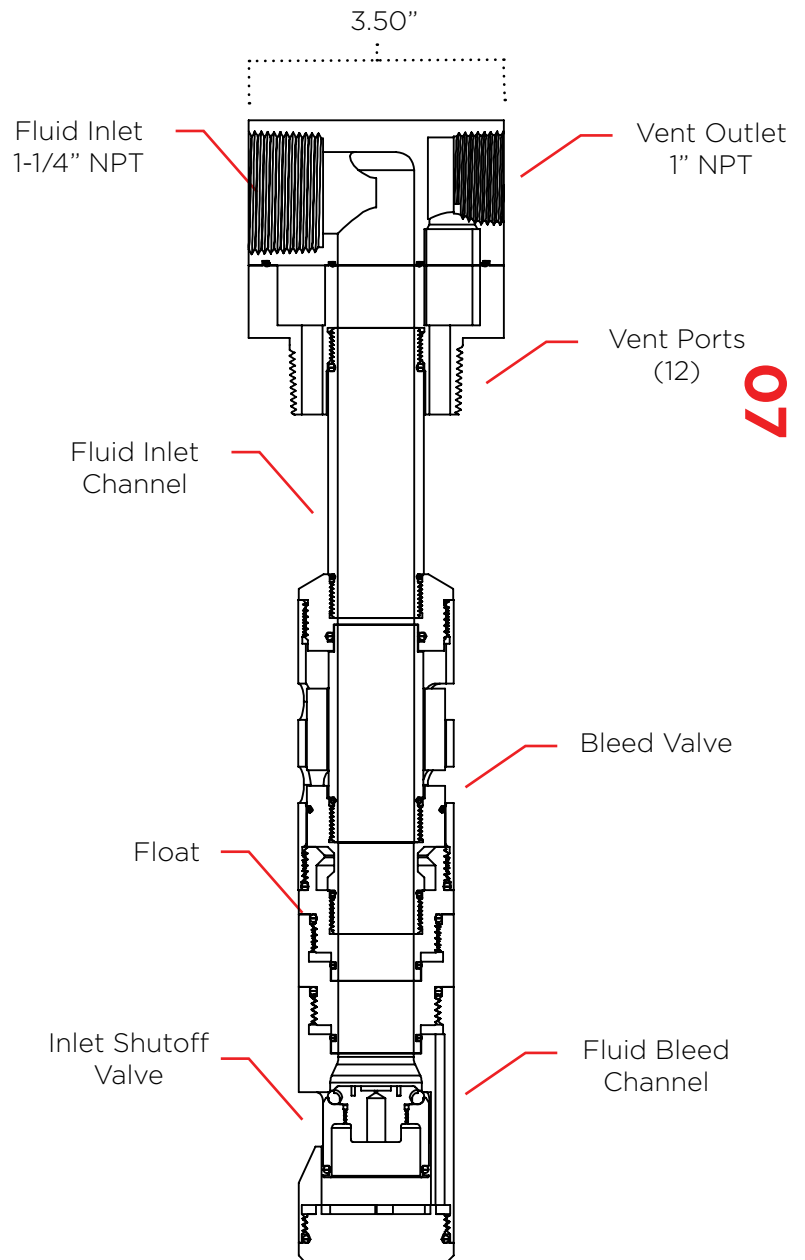
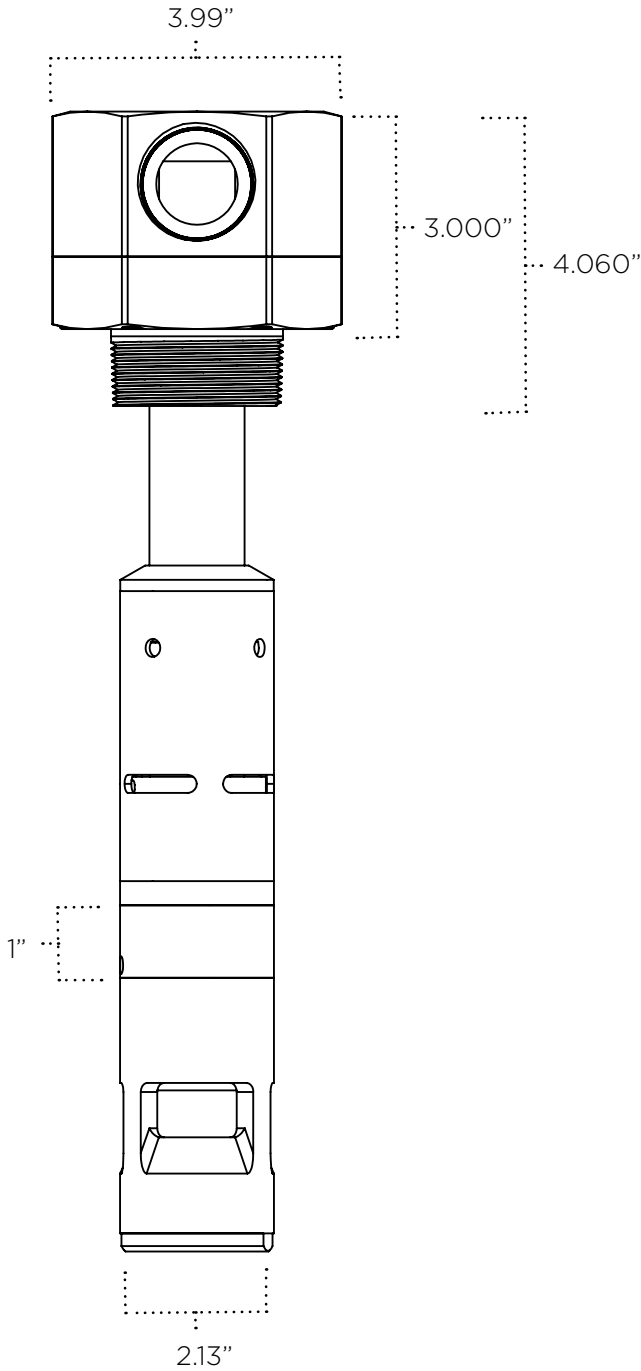

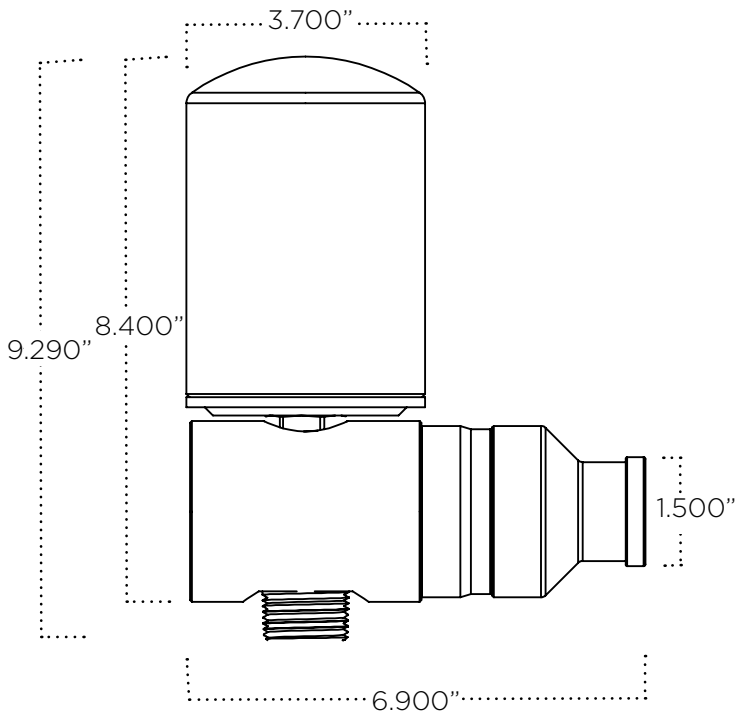

FFV150-PLR
Direct Mount Filter Vent w/
1.5" Hose Barb

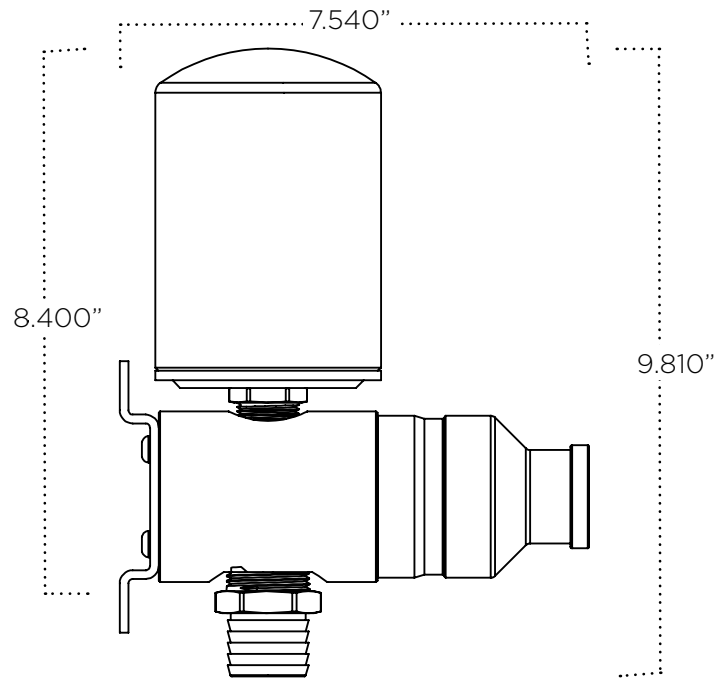

FFV150-R
Direct Mount Filter Vent w/
1.5" Hose Barb x 1.25" Hose

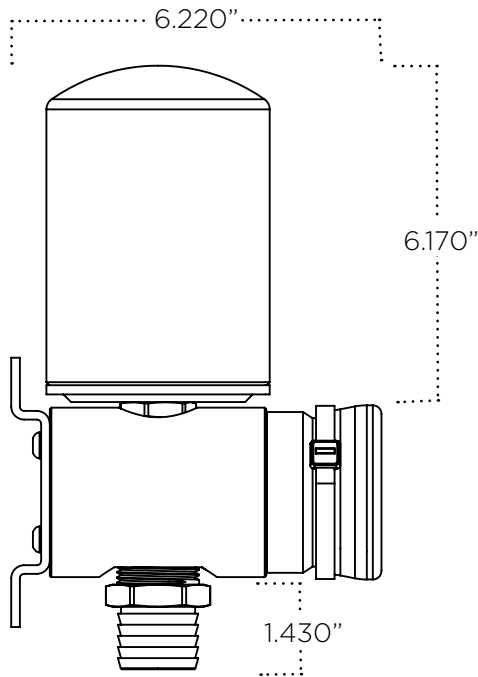

FFV150
Remote Mount Filter Vent
w/ Standard Dust Cap

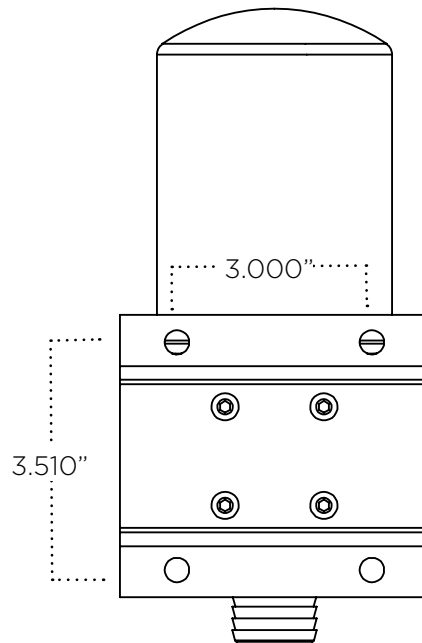

FAST FILL SYSTEMS

PART SPECIFICATIONS AND RECOMMENDATIONS

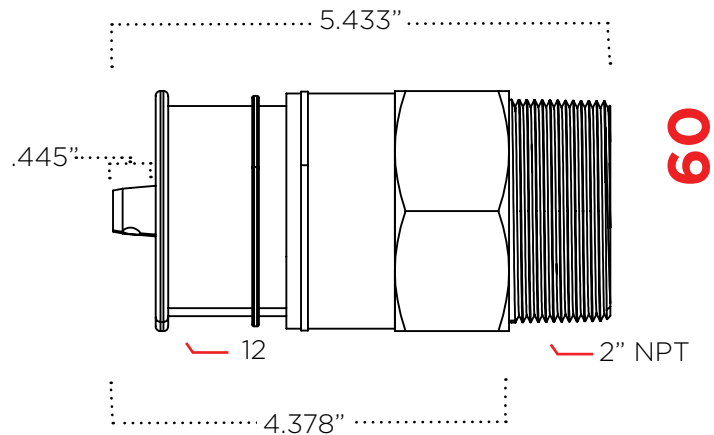
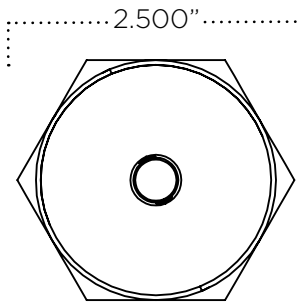
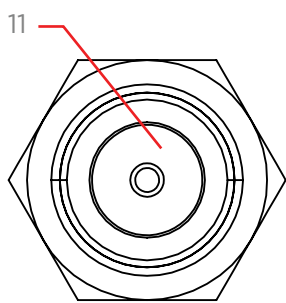
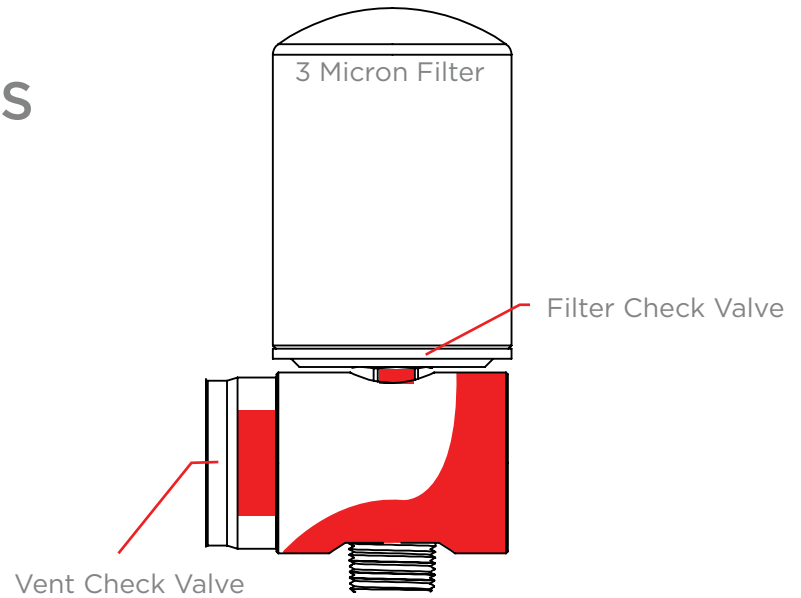
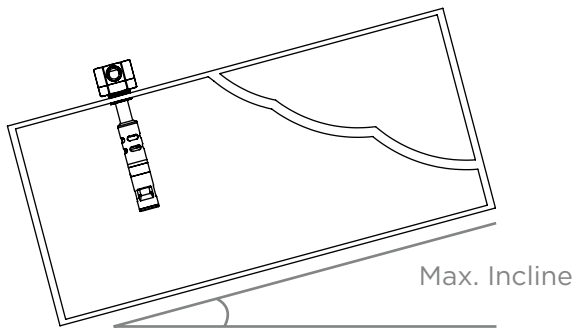

FEATURES:

- 11 -- Receiver Poppet (Green)
- 12 -- Plastic Cap and Dust Boot w/ lanyard

Special Instructions

- Remote FFV150 must be secured above the tank max fluid level at max incline (see Fig. 3a)
- IMPORTANT: Inspect for dirt / debris under the Vent Check Valve during regular maintenance
- IMPORTANT: Replace Spin-on Filter as needed
- See Fig. 3b for Discharge Check Valve, 3-Micron Filter and Breather Check Valve operation
- Low Profile Filter Fuel Vents are also available; Overall head height is less than 4.500" (11.43 cm)
- Secure the receiver to the remote supply line where the nozzle operator will stand

N150PB PitBoss

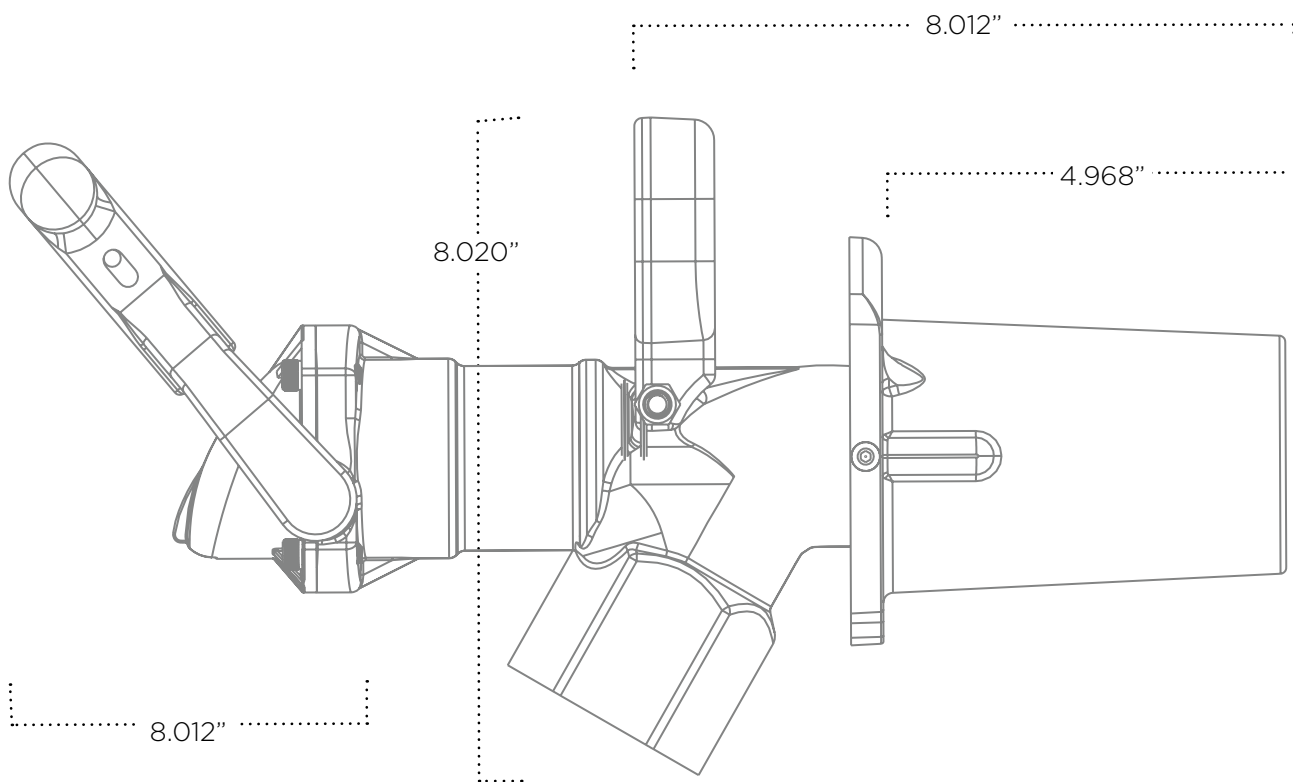
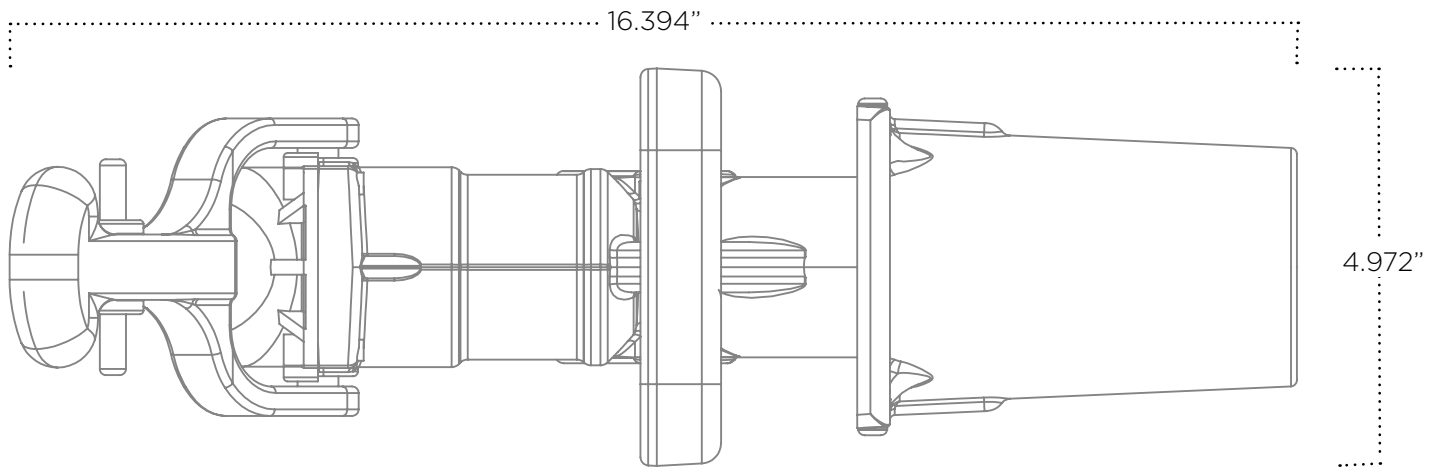

FAST FILL SYSTEMS

Max Operating Pressure	Max Flow Rate	Min Flow Rate	Fuel Inlet Threads	Weight	Latching Mechanism
8.6 BAR 125 PSI	567 LPM 150 GPM	95 LPM 25 GPM	1-1/2" NPT	3.3 KG 7.3 LBS	Elastodog Clips

PLA80 INSTALLATION INSTRUCTIONS

1. Determine the correct tank shutoff level. Ullage by Volume of 7-10% is recommended for adequate thermal expansion room and required shutoff time for low flow rates (ranging from 20 GPM to 80 GPM). Please visit our website to use our Tank Ullage Calculator: <http://www.fastfillsystems.com/downloads.htm>

2. Adjust the inserted length of the PLA80-SVLC to the correct shutoff level depth by adding the correct Drop Down Tube (part no. pl80-mz-1a = 2" length; part no. pl80-mz-1b = 3" length and part no. pl80-mz-1c = 4" length). Use the Medium Strength Loctite Threadlocker (blue) to lock the tubes in place, which prevents parts from vibrating loose.

3. Place Pipe Dope or Teflon Thread Tape on the 2" NPT threads of the PLA80-SVLC. Insert the PLA80-SVLC into the 2" NPT port of the tank (if the tank needs a 2" NPT port, please use the Welded Half Coupling, FV-P-8, or the Plastic Tank Flange, PLA150-M PTF). Secure the PLA80-SVLC down tight with a pipe wrench. CAUTION: Do not damage the 1" Vent Port threads or the 1-1/4" Inlet Port threads with the pipe wrench!

4. Install supply line piping (the PLA80-SVLC is remote mount only). We recommend 2" ID minimum piping or hose for best results. The piping or hose must be reduced with the proper bushing to fit the 1-1/4" Inlet Port.

5. Install the Filtered Fuel Vent (see Options 1-4 on page 5 of this instruction sheet) and all remote Vent Hosing and intake/discharge redirects (if applicable). We recommend 2" ID minimum vent hosing if remote mounting the Filter Fuel Vent further than 10-feet (3.28 m) away from the PLA80-SVLC.

CAUTION: Avoid any P-traps or sagging in the remote vent hosing!

6. Install the Remote Mount Fuel Receiver for Pressureless Systems (R150Sc-J). Use Pipe Dope or Teflon Thread Tape on the male threads of the receiver so prevent leaking.

7. Conduct the initially fueling and shutoff test with the recommended Fast Fill Systems Nozzle or equivalent industry nozzle with automatic shutoff ask your Sales Representative or Engineer for help, and consult the PLA80-SVLC Specification Sheet, and understand the capabilities and limitations with using this system with automatic shutoff nozzles.

Finally, if you have trouble with this system during initial fueling or during subsequent refuels, please contact your Fast Fill Systems representatives and your authorized distributor for help. Also, consult the Pressureless System Owner's Manual for Troubleshooting Steps.

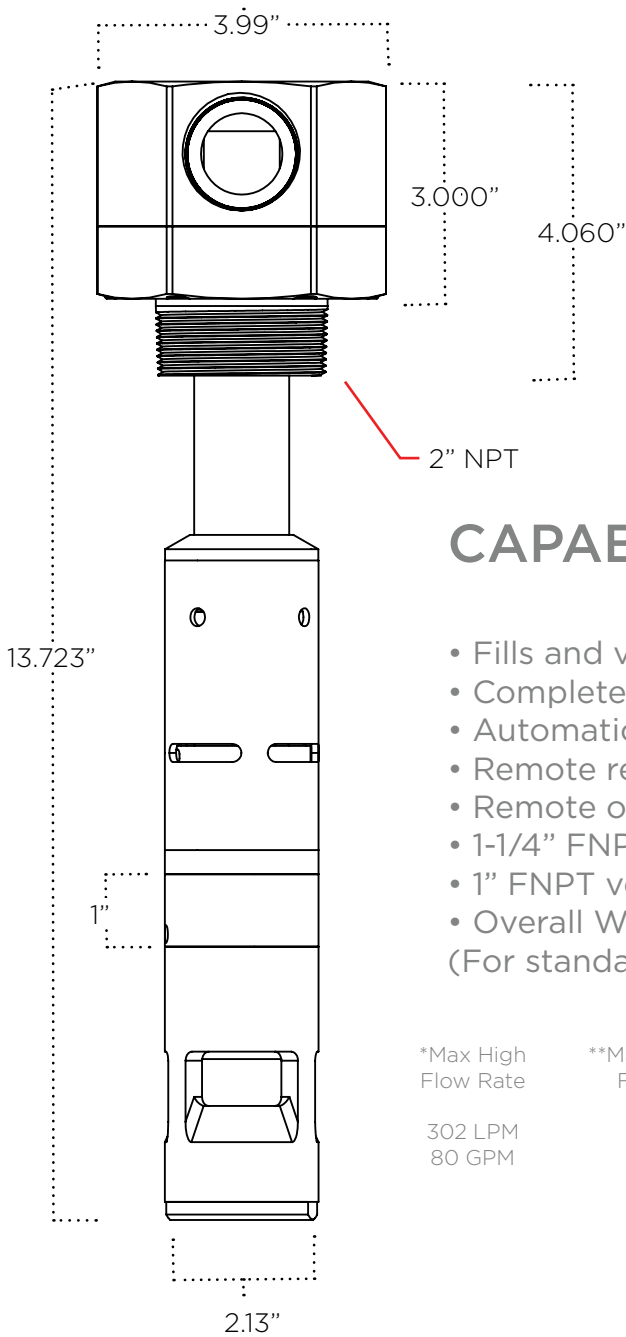

CAPABILITIES:

- Fills and vents through the same port
- Completely pressureless operation
- Automatic independent tank shutoff
- Remote receiver mounting
- Remote or direct filter vent mounting
- 1-1/4" FNPT Fuel inlet threads
- 1" FNPT vent port threads
- Overall Weight: 3.92 LBS | 1.78 KG
(For standard length tube)

*Max High
Flow Rate

302 LPM
80 GPM

**Max Standard
Flow Rate

151 LPM
40 GPM

Min Flow Rate

23.6 LPM
5 GPM

Max Operating
Temperature

150° F
65.6° C

Min Operating
Temperature

-30° F
-34.4° C



FAST FILL SYSTEMS

Fast Fill Systems is constantly innovating to meet the needs of the fast fueling industry. The PLA80-SVLC is an “all-in-one” drop-down tube that fits standard 2” NPT inlets. It eliminates the need for pressurized tanks or splash filling adapters, while simultaneously addressing the common problems of under / over filling multiple tanks in daisy-chain configurations. With the PLA80-SVLC installed, each tank will shutoff independently once the fuel level reaches 90-95% capacity. automatic shutoff works with all standard fuel nozzles (up to 40 gpm) and with high-flow fuel nozzles (up to 80 GPM). this product is ideal for agriculture, small construction, oil extraction and mass transit equipment because of its compact nature and ease of installation.



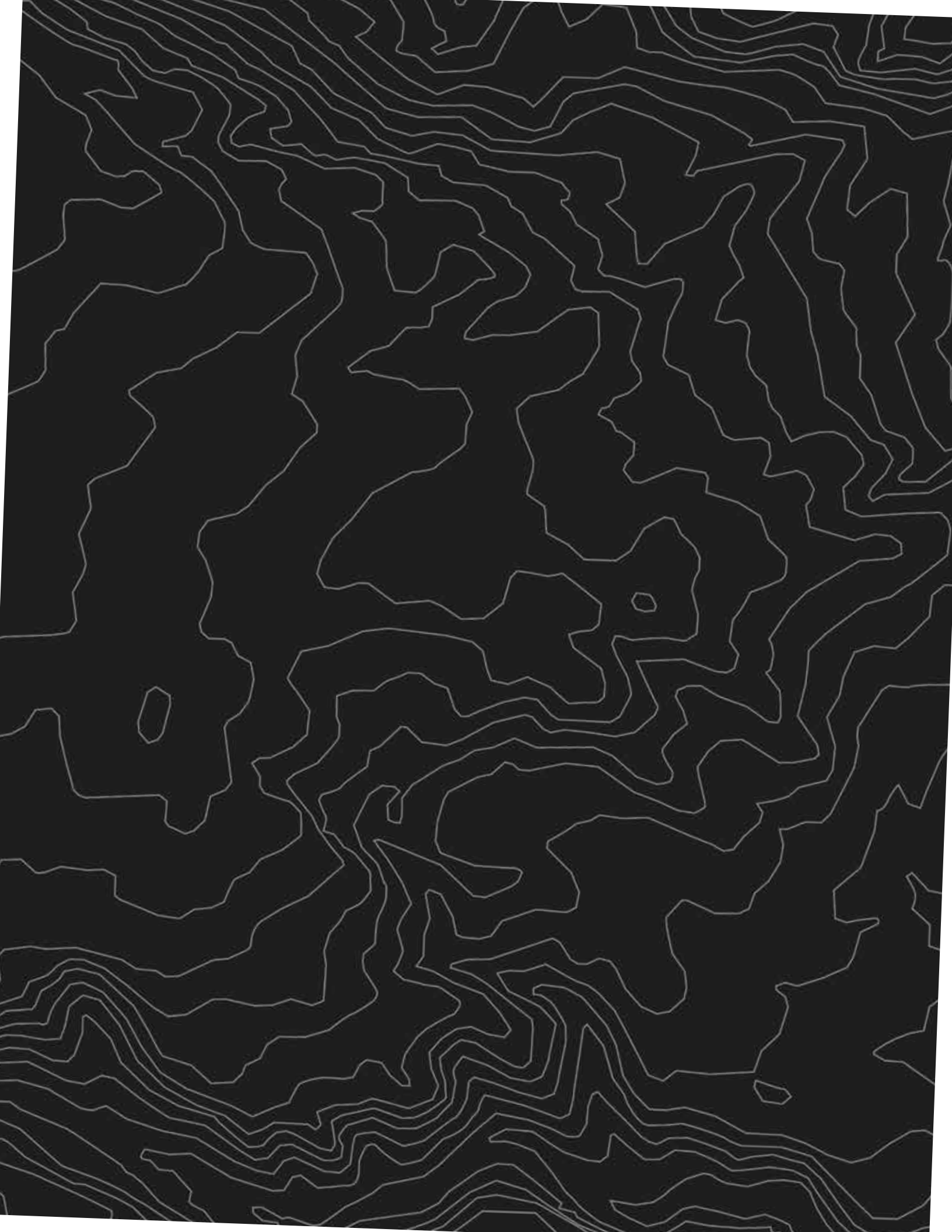

801.491.3600 // orders@fastfillsystems.com // www.fastfillsystems.com

