

SILVERI ENGINEERING & TRADING

ENGINE OIL TRANSFER | AUTO LUBE | SIMULATED AUTOMATIC WASH | FIRE SUPPRESSION | WORKSHOP EQUIPMENT



FAST FILL SYSTEMS

PRODUCT & TECHNICAL CATALOGUE

2026

WWW.SILVERIENG.COM

SALES@SILVERIENG.COM

1300 766 413

+61 3 9427 2117





CONTENTS

PAGE 2	INTRODUCTION
PAGE 3	DIESEL FUELING SYSTEMS
PAGE 4	N150AT ATLAS DIESEL NOZZLE (600 Litres)
PAGE 5	N800AT ATLAS DIESEL NOZZLE (800 Litres)
PAGE 6	N150PB PITBOSS DIESEL NOZZLE
PAGE 7	N150PSL SURELOC DIESEL NOZZLE
PAGE 8	N150C CLASSIS NOZZLE
PAGE 9	N1000PSL DIESEL NOZZLE
PAGE 10	SWIVELS
PAGE 11	R150CV CHECK VALVE (600 Litres)
PAGE 12	R800CV CHECK VALVE (800 Litres)
PAGE 13	STANDARD DIESEL RECEIVERS
PAGE 14	DIESEL VENTS - PRESSURE
PAGE 15	DIESEL VENTS - PRESSURELESS
PAGE 16	SERVICE BOX
PAGE 17	PLA80-HVSC PRESSURELESS SYSTEM HIGH VISCOSITY OILS
PAGE 18	PLA80-SVLC PRESSURELESS SYSTEM DIESEL SYSTEM
PAGE 19	PLFC-1 125 CONTINUOUS FUEL LEVEL REGULATOR
PAGE 20	PLFC-1 CONTINUOUS FUEL LEVEL REGULATOR
PAGE 21	PLA150 PRESSURELESS SYSTEM
PAGE 22	CHECK VALVE & ADAPTER ACCESSORIES
PAGE 23	PLA1000 PRESSURELESS SYSTEM
PAGE 24 - 28	MATRIX RECEIVERS AND NOZZLES
PAGE 28	STANDARD COUPLERS – CRANKCASE
PAGE 29	STANDARD COUPLERS – COOLANT
PAGE 30	STANDARD COUPLERS – HYDRAULIC
PAGE 31	STANDARD COUPLERS – TRANSMISSION
PAGE 32	STANDARD COUPLERS COLOURED RANGE – (Flomax cross over)
PAGE 29-32	STANDARD COUPLERS – DIMENSIONAL INFORMATION
PAGE 33-41	R SERIES COUPLERS - DIMENSIONAL INFORMATION
PAGE 42-46	MATRIX DIMENSIONAL INFORMATION
PAGE 47 - 60	PRESSURELESS APPLICATIONS
PAGE 61	CONTACT INFORMATION



Silveri Engineering & Trading Pty Ltd commenced operations in May 2018 with the objective of delivering reliable and effective service solutions to the mining, quarrying, and industrial sectors — both nationally and internationally.

Based in Australia, we specialise in import and export services, supporting international customers across Indonesia, Vietnam, the Philippines, Laos, Thailand, Papua New Guinea, and New Zealand, while servicing the Australian market extensively.

We have built a strong track record for excellent customer satisfaction, underpinned by our commitment to quality products and dependable service.

At Silveri Engineering & Trading, we do not compromise on quality. We believe in building long-term partnerships by ensuring our customers remain fully supported through responsive communication, technical capability, and exceptional service delivery.



DIESEL FUELING SYSTEMS

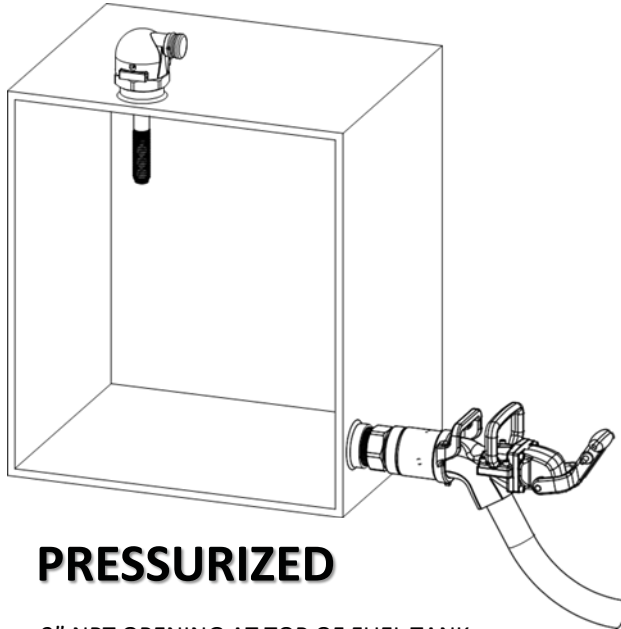

PRESSURIZED

2" NPT OPENING AT TOP OF FUEL TANK
2" NPT OPENING AT BOTTOM OF FUEL TANK
FUEL VENT (V150)
DIESEL FUEL RECEIVER (R150S)
DIESEL FUEL NOZZLE (N150AT)

HOW THE SYSTEM WORKS:

The standard fuelling system works on a sealed tank system. The fuel nozzle is connected to the fuel receiver located at the bottom of the fuel tank. The fuel nozzle handle is then turned to the "on" position and the pump begins pumping the diesel fuel into the fuel tank. Air will escape through the vent located at the top of the fuel tank as the tank continues to fill. When the diesel fuel reaches the desired level, the plastic balls in the vent ball cage will rise with the diesel fuel and seal on the O-ring so that air can no longer escape from the fuel tank. When this happens, pressure rapidly builds within the fuel tank. The fuel nozzle will sense this pressure and automatically shut-off; stopping the flow of fuel to the fuel tank. The fuel nozzles are calibrated to shut-off between 7-9 psi.

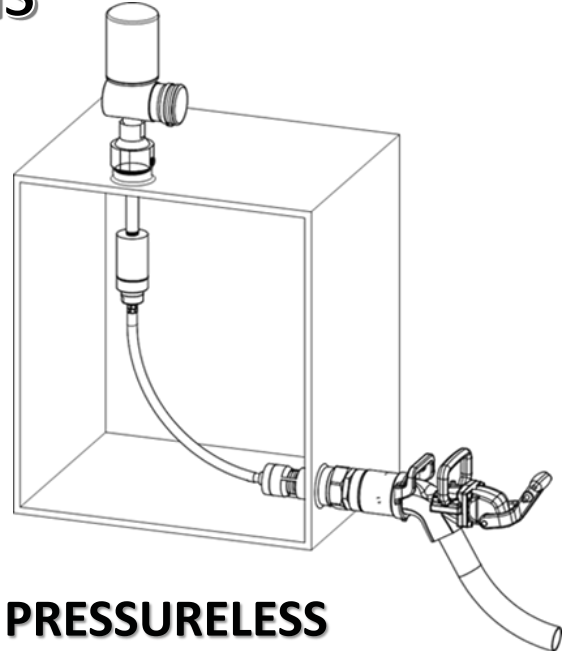

PRESSURELESS

2" NPT OPENING AT TOP OF FUEL TANK
2" NPT OPENING AT BOTTOM OF FUEL TANK
PLA150-M W/ FFV150-PL
(INCLUDES: PLA150-M SV, R150CVRC-J,
PLA150-M VLCE, FFV150-PL, AND PL-P-6)

HOW THE SYSTEM WORKS:

The pressureless fuelling system eliminates tank pressure. The fuel nozzle is connected to the fuel receiver located at the bottom of the fuel tank. The fuel nozzle handle is then turned to the "on" position and the pump begins pumping the diesel fuel into the fuel tank. Air will escape through the Vent Level Controller located at the top of the fuel tank as the tank continues to fill. When the diesel fuel reaches the desired level, the float in the Vent Level Controller will rise and seal on the internal O-ring so that fuel can no longer escape through the signal line. When this happens, back pressure rapidly builds within the Signal Line, closing the diaphragm in the Shut off Valve. The fuel nozzle will sense this pressure and automatically shut-off; stopping the flow of fuel to the fuel tank. The fuel nozzles are calibrated to shut-off between 7-9 psi.

N150AT ATLASDIESEL NOZZLE



N150ATP REFUELING DIESEL NOZZLE WITH PLUG

The new compact refuelling nozzle is rated for flow rates up to 150 GPM (567 LPM). It has a durable stainless-steel nose on the actuating ring and can be fitted with an aluminium front-end for the lightest weight refuelling nozzle available or can be fitted with a stainless front-end for increased durability.

The N150AT uses twelve, stainless steel ball bearings to ensure a secure latching to the receiver.

Accessories: P150 Plug & Lanyard P150S Steel Plug & Lanyard

N150AT TECHNICAL INFORMATION	
MAX OPERATING:	8.6 BAR, 125 PSI
PRESSURE MAX FLOW:	567 LPM, 150 GPM RATE
MIN FLOW RATE:	95 LPM, 25 GPM
FUEL INLET THREADS:	1-1/2" NPT
WEIGHT:	ALUMINIUM 2.6 KG, 5.6 LBS, STAINLESS STEEL, 2.89 KG 6.38 LBS
LATCHING MECHANISM:	STAINLESS BALL BEARINGS



S150, S512, S200, S215

STRAIGHT HOSE SWIVELS

Straight hose swivels with all aluminium construction

N800AT ATLAS DIESEL NOZZLE



N800ATP REFUELING DIESEL NOZZLE WITH PLUG

The new compact refuelling nozzle is rated for flow rates up to 211 GPM (800 LPM). It has a durable stainless-steel nose on the actuating ring and can be fitted with an aluminium front-end for the lightest weight refuelling nozzle available or can be fitted with a stainless front-end for increased durability.

The N800AT uses twelve, stainless steel ball bearings to ensure a secure latching to the receiver.

Accessories: P150 Plug & Lanyard P150S Steel Plug & Lanyard

N800AT TECHNICAL INFORMATION	
MAX OPERATING:	8.6 BAR, 125 PSI
PRESSURE MAX FLOW:	800 LPM, 211 GPM RATE
MIN FLOW RATE:	95 LPM, 25 GPM
FUEL INLET THREADS:	2" NPT
WEIGHT: ALUMINIUM/STAINLESS	2.6 KG, 5.37 LBS, STAINLESS STEEL, 2.89 KG 6.38 LBS
LATCHING MECHANISM:	STAINLESS BALL BEARINGS



**S150, S512, S200, S215
STRAIGHT HOSE SWIVELS**

Straight hose swivels with all aluminium construction

N150PB PIT BOSS DIESEL NOZZLE



N150PBP PIT BOSS REFUELING NOZZLE WITH PLUG

The Pit boss diesel fuel nozzle is a perfect fit for a more economic solution. The latching device of this nozzle is most forgiving model in muddy or severely dirty environments. Fewer internal components and a compact housing make this one of the lightest diesel nozzles available. With all metal construction, piston driven engagement, and a familiar non-slip powder-coat finish.

Accessories: P150 Plug & Lanyard P150S Steel Plug & Lanyard

N150PB TECHNICAL INFORMATION	
MAX OPERATING:	5.17 BAR, 75 PSI
PRESSURE MAX FLOW:	567 LPM, 150 GPM RATE
MIN FLOW RATE:	95 LPM, 25 GPM
FUEL INLET THREADS:	1-1/2" NPT
WEIGHT: ALUMINIUM	2.9 KG,
LATCHING MECHANISM:	ELASTODOG

PIT BOSS OPTIONS

N150PBHD Pit Boss Heavy-Duty Refuelling Nozzle All-steel

N150PB-BR Pit Boss Refuelling Nozzle-Brine Resistant

N150PBU Pit Boss Under Ground Refuelling Nozzle-



S150, S512, S200, S215 STRAIGHT HOSE SWIVELS

Straight hose swivels with all aluminium construction



N150PSL SURELOC DIESEL NOZZLE



N150SLP SURELOC DIESEL FUEL NOZZLE WITH PLUG

Proven reliable even in the harshest environments and is customizable to meet specific needs. Its durable, all metal construction and thick wall main housing makes it optimal for heavy duty operations. The latching mechanism consists of twelve stainless steel ball bearings for a secure latch. Available with either piston or diaphragm control shut-off and two flow rate and inlet options, it is our most versatile nozzle.

Accessories: P150 Plug & Lanyard P150S Steel Plug & Lanyard

N150PSL TECHNICAL INFORMATION	
MAX OPERATING:	5.17 BAR, 75 PSI
PRESSURE MAX FLOW:	567 LPM, 150 GPM RATE
MIN FLOW RATE:	95 LPM, 25 GPM
FUEL INLET THREADS:	1-1/2" NPT
WEIGHT: ALUMINIUM	3.6 KG,
LATCHING MECHANISM:	STAINLESS BALL BEARINGS

800 LITRE NOZZLE ALSO AVAILABLE N150SLP800



S150, S512, S200, S215 STRAIGHT HOSE SWIVELS

Straight hose swivels with all aluminium construction

N150C CLASSIC DIESEL NOZZLE



N150C CLASSIC DIESEL FUEL NOZZLE WITH PLUG

The N150C Classic Diesel Fuel Nozzle features traditional internal components that have been trusted across the heavy equipment industry for decades.

Constructed from durable all-metal materials, this nozzle delivers a familiar, proven design that operators know and rely on. With a long history as the industry standard for heavy equipment refuelling, the N150C offers dependable performance in demanding applications.

Accessories Included:

- P150 Plug
- Lanyard

N150C TECHNICAL INFORMATION	
MAX OPERATING:	5.17 BAR, 75 PSI
PRESSURE MAX FLOW:	567 LPM, 150 GPM RATE
MIN FLOW RATE:	95 LPM, 25 GPM
FUEL INLET THREADS:	1-1/2" NPT
WEIGHT: ALUMINIUM	3.51 KG,
LATCHING MECHANISM:	METAL LATCHING DOGS



**S150, S512, S200, S215
STRAIGHT HOSE SWIVELS**

Straight hose swivels with all aluminium construction



N1000PSL SURELOC DIESEL NOZZLE



N1000PSL SURELOC DIESEL FUEL NOZZLE WITH PLUG

The N1000PSL nozzle is rated for flow rates up to 1000 LPM (265 GPM), includes 2" NPT threads for an easy retrofit for exiting traditional fuelling receivers and vents. Utilizing our robust Piston Sureloc design the N1000PSL uses a 12-ball stainless ball-bearing latching mechanism ensuring a secure latch to the receiver.

- Powder coated non-slip finish for better grip.
- Sturdy build for greatly increased lifespan.
- Ball bearing latching for secure connection.
- Withstands extreme temperatures.

Accessories: P1000 Plug & Lanyard

N1000PSL TECHNICAL INFORMATION	
MAX OPERATING:	5.17 BAR, 75 PSI
PRESSURE MAX FLOW:	1000 LPM, 263 GPM RATE
MIN FLOW RATE:	95 LPM, 25 GPM
FUEL INLET THREADS:	1-1/2" NPT
WEIGHT: ALUMINIUM:	3.6 KG,
LATCHING MECHANISM:	BALL BEARING

N1000PSLP REQUIRES: PLA1000-M VLCE 1000 LPM Vent/Level Control
 PLA1000-M SV 1000 LPM Shut Off Valve
 N1000CVRC-J 1000 LPM Receiver



S150, S512, S200, S215 STRAIGHT HOSE SWIVELS

Straight hose swivels with all aluminium construction

SWIVELS FOR DIESEL NOZZLES



S75	3/4" SWIVEL
S100	1" SWIVEL
S125	HOSE SWIVEL 1 1/4"
S150	HOSE SWIVEL 1 1/2" STYLE BALL BEARING
S150-BSPT	HOSE SWIVEL 1 1/2" BSPT
S150 (MC)	SWIVEL 1 1/2" X 1 1/2"
S150R	1 3/4" NOZZLE REBUILD SWIVEL "B" STYLE BALL BEARING
S150S	STEEL HOSE SWIVEL 1 1/2"
S1510	HOSE SWIVEL 1 1/2"
S200	HOSE SWIVEL 2" "B" STYLE BALL BEARING
S200 (MC)	HOSE SWIVEL 2"
S215	HOSE SWIVEL 2" NPT MALE AND 1.5" FEMALE "B" STYLE BALL BEARING
S215S	STEEL HOSE SWIVEL WITH 2" NPT MALE THREADS AND 1.5" FEMALE
S512	HOSE SWIVEL 1 1/2" MALE NPT X 2" FEMALE NPT



AWS34B	SINGLE PLANE .75" BSP MALE/FEMALE
AWS34	SINGLE PLANE .75" NPT MALE/FEMALE
AWS10B	SINGLE PLANE 1" BSP MALE/FEMALE
AWS34B	SINGLE PLANE 1" NPT MALE/FEMALE

R150CV FUEL RECEIVER CHECK VALVE



R150CVC FUEL RECEIVER CHECKVALVE WITH CAP

The anodized aluminium check valve installs in the fuel tank to prevent fuel theft and allows the receiver to be replaced without draining the tank.

This patented Check Valve Receiver is a solution for any application. One-way check valve receiver for diesel fuel for use with pressurized shut-off configurations max flow rate 567 litres/min. Spray back is eliminated if the poppet gets stuck open from debris or poppet malfunction and fuel theft is minimized by making it harder to get the fuel out without the proper tools. With this Check Valve installed any receiver issues will be minimized to less than 6 fluid ounces of fuel loss.

- * Optional aluminium cap R150CVCA
 - * Optional Black Plastic Cap R150CVC
- Direct replacement for Wiggins ZN2CV.

R150CVSW

The R150CVSW is the check valve installation socket wrench. It is required to install or remove Fast Fill System's R150CV.



R800CV FUEL RECEIVER CHECK VALVE



The anodized aluminium check valve installs in the fuel tank to prevent fuel theft and allows the receiver to be replaced without draining the tank. This patented Check Valve Receiver is a solution for any application. One-way check valve receiver for diesel fuel for use with pressurized shut-off configurations max flow rate 800 litres/min. Spray back is eliminated if the poppet gets stuck open from debris or poppet malfunction and fuel theft is minimized by making it harder to get the fuel out without the proper tools. With this Check Valve installed any receiver issues will be minimized to less than 6 fluid ounces of fuel loss.

* Optional aluminium cap R150CVCA

* Optional Black Plastic Cap R150CVC

- Used with 567-800 Litre Diesel Nozzles
- Manufactured with Robust Materials
- Longer Seal Life
- Stronger Poppet Design
- Consistency of Flow Maintained

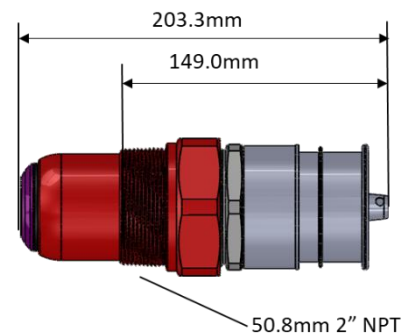

R150CVSW

The R150CVSW is the check valve installation socket wrench.



R150S FUEL RECEIVER



R150SC STANDARD DIESEL RECEIVER WITH CAP

Standard diesel fuel receiver is made from solid steel and is nickel-plated to ensure a long service life.

Designed to accommodate flow rates up to 800 LPM (211 GPM), Fast Fill Systems fuel receivers are completely compatible with all major manufacturers' diesel fuel nozzles. Available shutoff options: 7, 9, 11, and 12 PSI.

Direct replacement for:

- Wiggins ZNC2A
- Flomax FRS-C
- Optional aluminium Cap C150A



DIESEL RECEIVER OPTIONS	
R150A-A	FUEL RECEIVER (9 PSIG SHUT-OFF PRESSURE, BLACK POPPET) ALUMINUM
R150A-B	FUEL RECEIVER (11 PSIG SHUT-OFF PRESSURE, BLUE POPPET) ALUMINUM
R150A-D	FUEL RECEIVER (7 PSIG SHUT-OFF PRESSURE, RED POPPET) ALUMINUM
R150AC-A	FUEL RECEIVER WITH CAP – ALUM (9 PSIG SHUT OFF PRESS - BLACK POPPET)
R150AC-B	FUEL RECEIVER W/CAP (11 PSIG SHUT-OFF PRESSURE, BLUE POPPET - ALUM)
R150AC-D	FUEL RECEIVER W/CAP (7 PSIG SHUT-OFF PRESSURE, RED POPPET - ALUM)

VENTS FOR PRESSURISED DIESEL



V150A fuel vent with half coupling from Fast Fill Systems.

This vent is commonly used when retrofitting fast fuelling equipment on splash fill diesel tanks that have no existing vent port.



V150 The basic fuel vent available with a standard 5", 7" (V150L7), and 12" (V150L12) stems.



V150SR used with the V150 where additional over-fill relief is needed. A safety relief valve protects the tank from over filling if a nozzle fails. Opens tank when pressure hits over 13 PSI.



V150H Designed for fuel rates exceeding 150 GPM, capable of reaching 300 GPM. Compatible with all vent configurations.



V150C Allows for easy hose attachment with a 1" FNPT swivel adapter on the opening of the vent cap.



V150B Commonly used where 2" NPT ports are not available. Drill and tapping is required. Bolt on 2" NPT flange included. Nitrile seal



V150W Whistles when tank reaches internal pressures of 5-7 PSI. This creates a clear signal to operator that nozzle should be shutting off



V150F fuel vent incorporates the filtered protection of our FFV150 filter vent assembly directly into a compact vent cap. It includes our dual check valve design to ensure only filtered air enters the tank, and to protect your filter element from fuel vapours and sloshing. thereby extending its life.

VENTS FOR PRESSURELESS SYSTEMS



FFV150 BKT

The remote mount 3-micron filter with 2 check valves for airflow in and out has a low profile for variable placement and universal mounting bracket for easy installation for side or bottom mounting.



FFV150-LP

Direct or remote mount available Low profile horizontal configuration, use in low headroom locations



FFV150-PL

The direct mount 3-micron filter with 2 check valves for airflow in and out.



FFV-MF

3 Micron Replacement Filter (Filters must be replaced every 12 Months)



FFV150-VB1

Filter vent with Vacuum Break is used in conjunction with a desiccant filter (filter not included).



FFV150-HVVB

High Volume Filter Vent, ideal for large storage tanks, enlarged Filter Check Valve.



FFV150-BCKV

The breather check valve (3/4" NPT Male Thread) is used in conjunction with the vent with check valve V150H-CKH (2" NPT Male Base Thread).



SB100 SERVICE BOX

Boxes can be configured to house any number or type of receiver. By consolidating the location of Couplers, speed and safety are increased. Units can be coloured to customer preference.



A150A, A150B, A150C SPLASH FILL ADAPTERS

Used to splash fill a tank with any fast fill or standard diesel fueling nozzle.



BREAKAWAY COUPLERS

Hose safety breakaway coupler with female NPT threads.

- AB1 1" BREAKAWAY COUPLER
- AB14 1-1/4" BREAKAWAY COUPLER
- AB15 1-1/2" BREAKTIME COUPLING
- AB1BSP 1" BREAKAWAY COUPLER WITH BSP THREADS
- AB2 2" BREAKAWAY COUPLER
- AB3 3" BREAKAWAY COUPLER
- AB34 3/4" BREAKAWAY COUPLER



PLA80-HVSC



PLA80-HVSC opens auto-shutoff fluid transfer to high viscosity oils and fluids. This all-in-one system fits standard 2" NPT inlets. Once the fuel level reaches 90- 95% capacity, each tank will automatically shut-off eliminating under/over filling. Filtered venting and a dry break fill point decrease contamination. There are a broad range of applications due to its compact design and easy installations.

- Completely pressureless operation
- Low profile filter vent or remote mount
- Adjustable shut off level.
- Standard weight: 3.92 lbs | 1.78 kg
- Compatible with gear oil up to 680 cSt



Associated Hose and Fittings Supplied by customer.

Max Flow Rate 100 LPM 26.5 GPM	Min Flow Rate 23.6 LPM 5 GPM
Max Oper Temp 150 Deg F 65.6 Deg C	Min Oper Temp -30 Deg F -34.4 Deg C



FFV150-LP, LOW PROFILE- FILTER VENT



N150SB, BULK FILLING NOZZLE

PLA80-SVLC



The PLA80 brings Pressureless fuelling to applications where it was once unavailable. This all-in-one drop-in system fits standard 2" NPT inlets and enables individual tank fill and shutoff for single or multi tank configurations. Once the fuel level reaches 90-95% capacity, each tank will automatically shut off, eliminating under/over filling. The auto shut-off feature works with all standard fuel nozzles (up to 80 GPM). With filtered venting and a dry break fill point, contamination is dramatically decreased. Applications agriculture, small construction, oil extraction and mass transit equipment because of its compact design and ease of installation.

- Fills and vents through the same unit
- Completely pressureless operation
- Automatic independent tank shutoff
- Remote receiver mounting
- Remote or direct filter vent mounting
- 1-1/4" FNPT fuel inlet threads
- 1" FNPT vent port threads
- Standard weight: 3.92 lbs | 1.78 kg

Max Flow Rate 302 LPM 80 GPM	Min Flow Rate 151 LPM 4 GPM
Max Oper. Temp 150 Deg F 65.6 Deg C	Min Oper. Temp -30 Deg F -34.4 Deg C



FFV150-LP FILTER VENT



R150SC-J 12 PSI RECEIVER

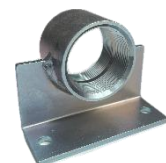

SMB2 2" MOUNTING

PLFC-1 125



LOW VOLUME PLA80 FOR CONTINUOUS FUEL LEVEL REGULATION

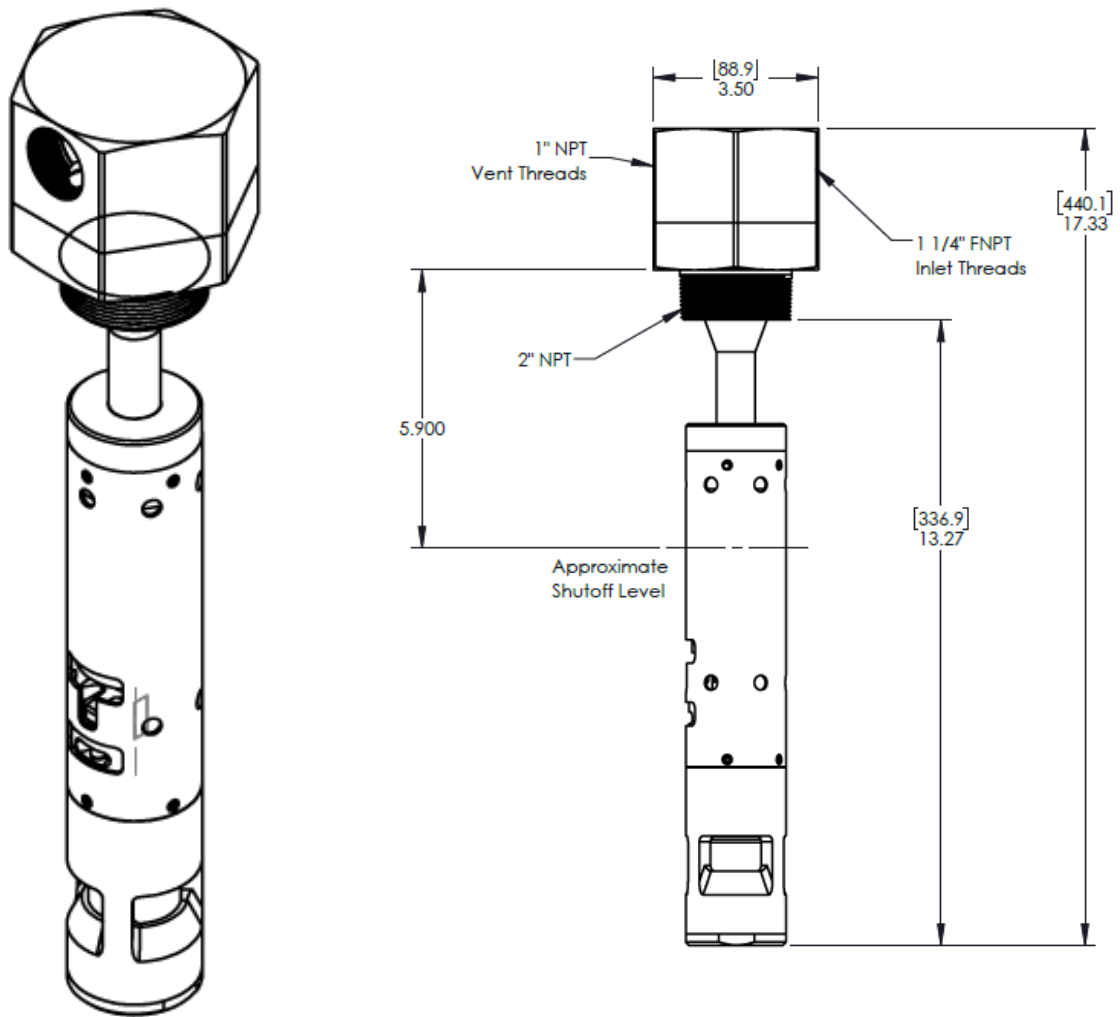

MAX PRESSURE: 60 PSI

MAX FLOW RATE: 30 GPM

PLFC-1



LOW VOLUME PLA80 FOR CONTINUOUS FUEL LEVEL REGULATION

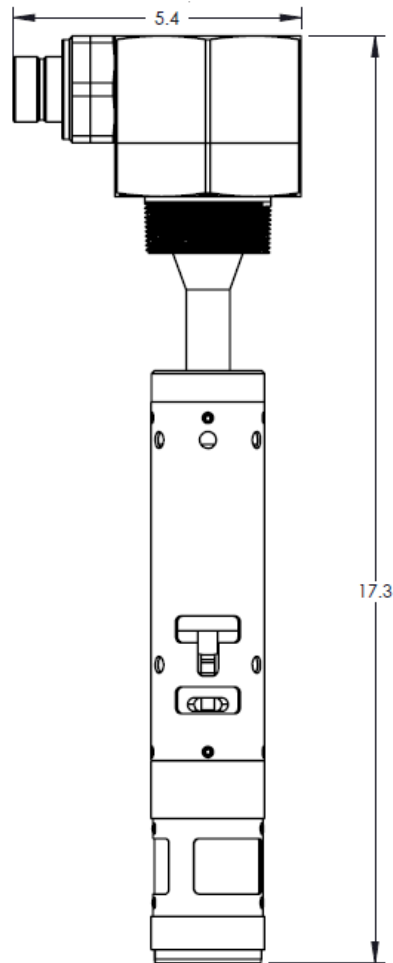
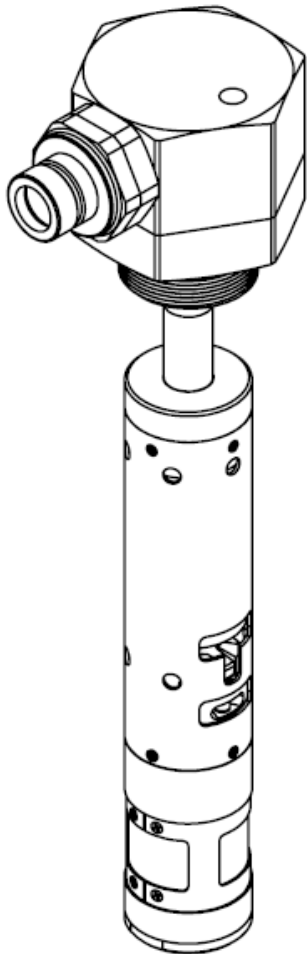

MAX PRESSURE: 60 PSI

MAX FLOW RATE: 30 GPM

PLA150—PRESSURELESS

Operates by a predetermined fuel level shut-off point. The system operates with zero pressure in the tank itself, giving accurate fuel levels and virtually eliminates costly fuel system failures. Its proven application in a wide-range of configurations for a diverse array of equipment such as internal or external signal lines, direct or remote-mount fuel receivers, and adjustable shut-off levels.

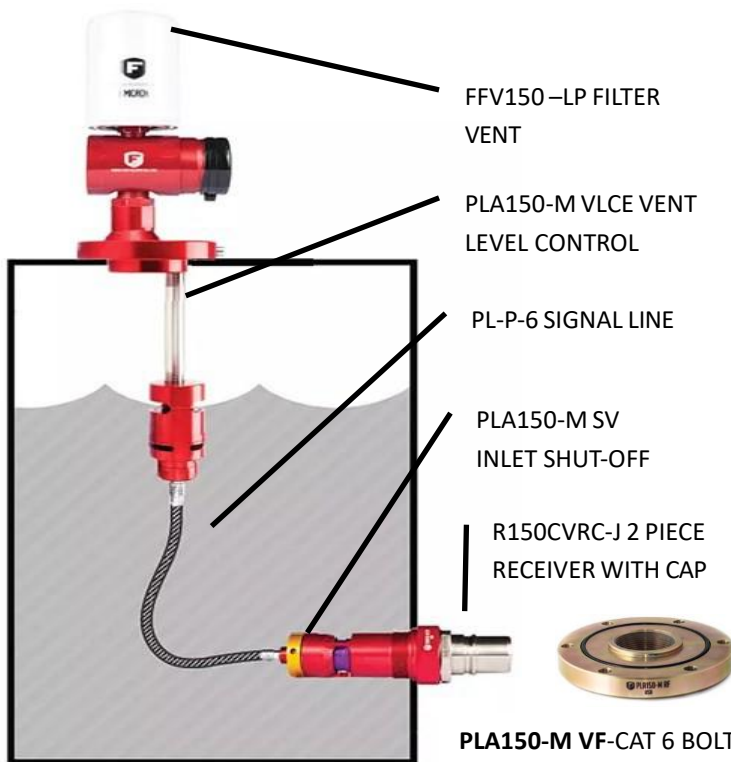

FFV150-LP FILTER VENT

PLA150-M VLCE VENT LEVEL CONTROL

PL-P-6 SIGNAL LINE

PLA150-M SV INLET SHUT-OFF

R150CVRC-J 2 PIECE RECEIVER WITH CAP

PLA150-M VF-CAT 6 BOLT VENT FLANGE ADAPTOR TO 2" NPT



FFF4C / FFF5C—WELD- ON / BOLT ON FLUSH MOUNT BELL HOUSING



FFF-6C-WOF—TANK FLANGE WELD, TO SUIT FFF5C 2" NPT



PLA150-M RF -CAT 6 BOLT RECEIVER FLANGE ADAPTOR TO 2" NPT



 **SMB2 2" NPT REMOTE MOUNTING BRACKET**



FV-P-8—2" HALF SOCKET



PLA150-M PTF—2" NPT FLANGE FOR PLASTIC TANK



PLA150-M SVFE—6 BOLT FLANGE W/ PRESSURELESS SHUTOFF VALVE ASSEMBLY W/ EXTERNAL SIGNAL LINE CONNECTIONS FOR 2 PC RECEIVER



PLA150-M SV61-E 6 BOLT FLANGE W/ PRESSURELESS SHUTOFF VALVE ASSY W/ CODE 61 FLANGE W/ EXTERNAL



PLA150-M SVEBH—BOLT-ON BELL HOUSING REPLACEMENT W/ SHUTOFF VALVE ASSY W/EXTERNAL SIGNAL LINE CONNECTION



PLA150-M RRR2—SHUTOFF VALVE MOUNTING "CAN" FOR EXTERNAL SIGNAL LINE INCLUDES 2 PC STEEL FUEL RECEIVER

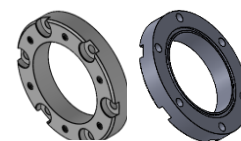

FFF6C - CAT 6 BOLT MOUNT FLANGE BOLT ON CAT

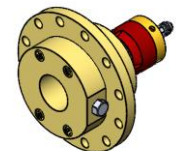

PLA150-M SV61-12 CAT FLANGE 12 BOLT

CHECK VALVE AND ADAPTOR ACCESSORIES



AD150J— 2" CHECK VALVE ADAPTOR W/JIC CONNECTION



AD150— 2" CHECK VALVE ADAPTOR CONNECTION



AD150JR
ADAPTOR 2" JIC MALE X 2" NPT FEMALE WITH OPTIONAL INDICATOR
**NOTE: RECEIVER IS SOLD SEPARATELY.



R150CVDT
CHECK VALVE DRAIN TOOL

PLA150-MDT
PRESSURELESS DRAIN TOOL

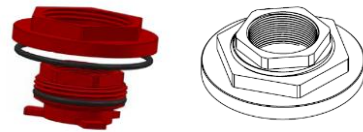

PLA80-SFA-TL4 CAT MODELS CAP ADAPTER (EG CAT 320)



PLA80-SFA-KW3 THREADED SPLASH FILL -2" NPT ADAPTOR

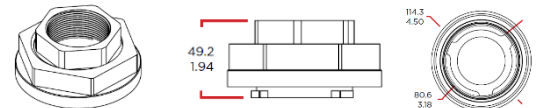

PLA80-SFA-PB3 THREADED SPLASH FILL -2" NPT ADAPTOR

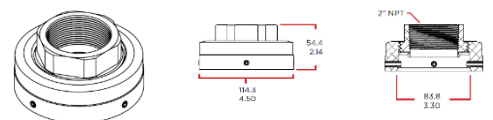

PLA80-SFA-WS3TL THREADED SPLASH FILL -2" NPT ADAPTOR



PLA80-M-PTSF
THREADED SPLASH FILL -2" NPT ADAPTOR

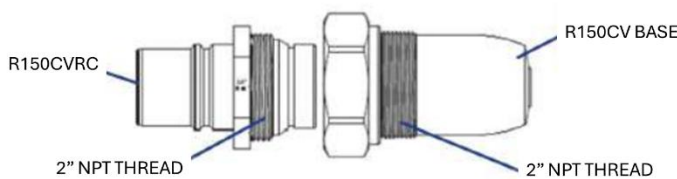

R150CV FUEL RECEIVER CHECK VALVE WITHOUT CAP – BLACK POPPET 9 PSIG SPRING. ENVIRONMENTALLY FRIENDLY, REDUCE RECEIVER LEAKS, ADD SAFETY, HELP (ALSO, AVAILABLE IN STEEL)



R150CVR CHECK VALVE REPLACEMENT RECEIVER WITH BLACK POPPET AND 9 PSIG SPRING FOR PRESSURISED AND STANDARD SYSTEM, ALSO AVAILABLE FOR PRESSURELESS SYSTEMS R150CVR-J. **NOTE: THESE UNITS ARE NOT INTERCHANGEABLE WITH STANDARD RECEIVERS (R150*)



R150-TL70CV 70MM TWIST LOCK FUEL RECEIVER CHECK VALVE

PLA1000-M VLCE – HIGH VOLUME



When combined with the N1000PSLP nozzle, the PLA1000-M SV, flow rates of up to 1000 LPM are achievable. With pressureless operation, this system provides your operators a clean & safe way to refuel high volume applications. With increased flow around the closed-cell encapsulated foam float, our system maintains reliability at higher flow rates. Other features include external and internal signal line ports and integrated roll over spill protection. The VLCE is precisely engineered to function on the largest tanks with only 4" of operating head space. (16" of clearance required for installation.)

- Automatic shut-off without inducing pressure into the tank.
- Positive shut-off system senses the fluid level in the tank.
- Diesel-resistant closed-cell foam float for shut-off.
- 2" NPT easily fits most tank applications
- Max Operating Pressure 5.17 Bar, 75PSI



PLA1000-M SV

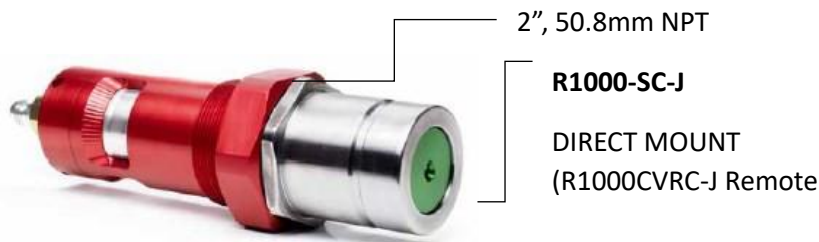

N1000PSLP (see page 8 for technical information)

This high flow receiver can handle the most demanding high-volume applications. When paired with an N1000PSLP nozzle and our PLA1000-M VLCE. Made of extremely durable nickel-plated steel, this receiver will last in the harshest environments. The new enclosed spring design smooths fluid flow to prevent vibrations caused by high flow rates.

MATRIX NOZZLES & RECEIVERS – OIL & FLUID TRANSFER



MATRIX 34 STANDARD NOZZLES AND RECEIVERS (200/300 SERIES)

NOZZLE WITHOUT PLUG, SEPARATELY SOLD			
PART NO	DESCRIPTION	PLUG	PLUG COLOUR
N210	FASTFILL MATRIX 3/4" NOZZLE	P310	GREEN
N220	FASTFILL MATRIX 3/4" NOZZLE	P320	BLUE
N230	FASTFILL MATRIX 3/4" NOZZLE	P330	PURPLE
N240	FASTFILL MATRIX 3/4" NOZZLE	P340	GREY
N250	FASTFILL MATRIX 3/4" NOZZLE	P350	ORANGE
N260	FASTFILL MATRIX 3/4" NOZZLE	P360	YELLOW
N270	FASTFILL MATRIX 3/4" NOZZLE	P370	RED
N280	FASTFILL MATRIX 3/4" NOZZLE	P380	GOLD
N205	FASTFILL MATRIX 3/4" NOZZLE	P305	HOT PINK
N207	FASTFILL MATRIX 3/4" NOZZLE	P307	BROWN

NOZZLE WITH PLUG		
PART NO	DESCRIPTION	PLUG COLOUR
N210P	FASTFILL MATRIX 3/4" NOZZLE WITH PLUG	GREEN
N220P	FASTFILL MATRIX 3/4" NOZZLE WITH PLUG	BLUE
N230P	FASTFILL MATRIX 3/4" NOZZLE WITH PLUG	PURPLE
N240P	FASTFILL MATRIX 3/4" NOZZLE WITH PLUG	GREY
N250P	FASTFILL MATRIX 3/4" NOZZLE WITH PLUG	ORANGE
N260P	FASTFILL MATRIX 3/4" NOZZLE WITH PLUG	YELLOW
N270P	FASTFILL MATRIX 3/4" NOZZLE WITH PLUG	RED
N280P	FASTFILL MATRIX 3/4" NOZZLE WITH PLUG	GOLD
N205P	FASTFILL MATRIX 3/4" NOZZLE WITH PLUG	HOT PINK
N207P	FASTFILL MATRIX 3/4" NOZZLE WITH PLUG	BROWN

NOZZLE WITHOUT PLUG, SEPARATELY SOLD			
PART NO	DESCRIPTION	PLUG	PLUG COLOUR
N310	FASTFILL MATRIX 3/4" NOZZLE	P310	GREEN
N320	FASTFILL MATRIX 3/4" NOZZLE	P320	BLUE
N330	FASTFILL MATRIX 3/4" NOZZLE	P330	PURPLE
N340	FASTFILL MATRIX 3/4" NOZZLE	P340	GREY
N350	FASTFILL MATRIX 3/4" NOZZLE	P350	ORANGE
N360	FASTFILL MATRIX 3/4" NOZZLE	P360	YELLOW
N370	FASTFILL MATRIX 3/4" NOZZLE	P370	RED
N380	FASTFILL MATRIX 3/4" NOZZLE	P380	GOLD
N305	FASTFILL MATRIX 3/4" NOZZLE	P305	HOT PINK
N307	FASTFILL MATRIX 3/4" NOZZLE	P307	BROWN

NOZZLE WITH PLUG		
PART NO	DESCRIPTION	PLUG COLOUR
N310P	FASTFILL MATRIX 3/4" NOZZLE WITH PLUG	GREEN
N320P	FASTFILL MATRIX 3/4" NOZZLE WITH PLUG	BLUE
N330P	FASTFILL MATRIX 3/4" NOZZLE WITH PLUG	PURPLE
N340P	FASTFILL MATRIX 3/4" NOZZLE WITH PLUG	GREY
N350P	FASTFILL MATRIX 3/4" NOZZLE WITH PLUG	ORANGE
N360P	FASTFILL MATRIX 3/4" NOZZLE WITH PLUG	YELLOW
N370P	FASTFILL MATRIX 3/4" NOZZLE WITH PLUG	RED
N380P	FASTFILL MATRIX 3/4" NOZZLE WITH PLUG	GOLD
N305P	FASTFILL MATRIX 3/4" NOZZLE WITH PLUG	HOT PINK
N307P	FASTFILL MATRIX 3/4" NOZZLE WITH PLUG	BROWN

RECEIVER WITHOUT CAP, SEPARATELY SOLD			
PART NO	DESCRIPTION	PLUG	PLUG COLOUR
R310	FASTFILL MATRIX 3/4" RECEIVER	C310	GREEN
R320	FASTFILL MATRIX 3/4" RECEIVER	C320	BLUE
R330	FASTFILL MATRIX 3/4" RECEIVER	C330	PURPLE
R340	FASTFILL MATRIX 3/4" RECEIVER	C340	GREY
R350	FASTFILL MATRIX 3/4" RECEIVER	C350	ORANGE
R360	FASTFILL MATRIX 3/4" RECEIVER	C360	YELLOW
R370	FASTFILL MATRIX 3/4" RECEIVER	C370	RED
R380	FASTFILL MATRIX 3/4" RECEIVER	C380	GOLD
R305	FASTFILL MATRIX 3/4" RECEIVER	C305	HOT PINK
R307	FASTFILL MATRIX 3/4" RECEIVER	C307	BROWN

RECEIVER WITH CAP		
PART NO	DESCRIPTION	PLUG COLOUR
R310C	FASTFILL MATRIX 3/4" RECEIVER WITH CAP	GREEN
R320C	FASTFILL MATRIX 3/4" RECEIVER WITH CAP	BLUE
R330C	FASTFILL MATRIX 3/4" RECEIVER WITH CAP	PURPLE
R340C	FASTFILL MATRIX 3/4" RECEIVER WITH CAP	GREY
R350C	FASTFILL MATRIX 3/4" RECEIVER WITH CAP	ORANGE
R360C	FASTFILL MATRIX 3/4" RECEIVER WITH CAP	YELLOW
R370C	FASTFILL MATRIX 3/4" RECEIVER WITH CAP	RED
R380C	FASTFILL MATRIX 3/4" RECEIVER WITH CAP	GOLD
R305C	FASTFILL MATRIX 3/4" RECEIVER WITH CAP	HOT PINK
R307C	FASTFILL MATRIX 3/4" RECEIVER WITH CAP	BROWN

OPERATING PRESSURE	103 BAR	1500 PSI
THREADS NOZZLE	3/4" FNPT	
RECEIVER	3/4" MNPT	
MATERIALS	Anodized Aluminium and Nickel plated Steel with Color-coding and keyed to prevent cross-contamination.	

Matrix 300 is a series of proprietary couplers designed to prevent cross-contamination of fluids. Matrix couplers work at a higher pressure and flow rate than standard couplers. Each of the nozzles and receivers in the matrix line is colour-coded and designed to physically interlock with only its matching colour. Higher flow rates than industry standard couplers. Helps eliminate cross-contamination of fluids. Interlocks only with corresponding colour-coordinated connector. All receivers are capable of JIC fitting.

MATRIX NOZZLES & RECEIVERS – OIL & FLUID TRANSFER



MATRIX 34 STANDARD NOZZLES AND RECEIVERS (200/300 SERIES)

RECEIVER VITON SEALS WITHOUT CAP, SEPARATELY SOLD			
PART NO	DESCRIPTION	PLUG	PLUG COLOUR
R310V	FASTFILL MATRIX 3/4" RECEIVER	C310	GREEN
R320V	FASTFILL MATRIX 3/4" RECEIVER	C320	BLUE
R330V	FASTFILL MATRIX 3/4" RECEIVER	C330	PURPLE
R340V	FASTFILL MATRIX 3/4" RECEIVER	C340	GREY
R350V	FASTFILL MATRIX 3/4" RECEIVER	C350	ORANGE
R360V	FASTFILL MATRIX 3/4" RECEIVER	C360	YELLOW
R370V	FASTFILL MATRIX 3/4" RECEIVER	C370	RED
R380V	FASTFILL MATRIX 3/4" RECEIVER	C380	GOLD
R305V	FASTFILL MATRIX 3/4" RECEIVER	C305	HOT PINK
R307V	FASTFILL MATRIX 3/4" RECEIVER	C307	BROWN

RECEIVER VITON SEALS WITH CAP		
PART NO	DESCRIPTION	PLUG COLOUR
R310VC	FASTFILL MATRIX 3/4" RECEIVER WITH CAP	GREEN
R320VC	FASTFILL MATRIX 3/4" RECEIVER WITH CAP	BLUE
R330VC	FASTFILL MATRIX 3/4" RECEIVER WITH CAP	PURPLE
R340VC	FASTFILL MATRIX 3/4" RECEIVER WITH CAP	GREY
R350VC	FASTFILL MATRIX 3/4" RECEIVER WITH CAP	ORANGE
R360VC	FASTFILL MATRIX 3/4" RECEIVER WITH CAP	YELLOW
R370VC	FASTFILL MATRIX 3/4" RECEIVER WITH CAP	RED
R380VC	FASTFILL MATRIX 3/4" RECEIVER WITH CAP	GOLD
R305VC	FASTFILL MATRIX 3/4" RECEIVER WITH CAP	HOT PINK
R307VC	FASTFILL MATRIX 3/4" RECEIVER WITH CAP	BROWN

	OPERATING PRESSURE	103 BAR	1500 PSI
THREADS	NOZZLE	3/4" FNPT	
	RECEIVER	3/4" MNPT	
MATERIALS	Anodized Aluminium and Nickel plated Steel with Color-coding and keyed to prevent cross-contamination.		



MATRIX 34 STANDARD NOZZLES AND RECEIVERS (200/300 SERIES) – 1" THREAD

NOZZLE WITHOUT PLUG, SEPARATELY SOLD			
PART NO	DESCRIPTION	PLUG	PLUG COLOUR
N310-1	FAST FILL MATRIX 1" NOZZLE	P310	GREEN
N320-1	FAST FILL MATRIX 1" NOZZLE	P320	BLUE
N330-1	FAST FILL MATRIX 1" NOZZLE	P330	PURPLE
N340-1	FAST FILL MATRIX 1" NOZZLE	P340	GREY
N350-1	FAST FILL MATRIX 1" NOZZLE	P350	ORANGE
N360-1	FAST FILL MATRIX 1" NOZZLE	P360	YELLOW
N370-1	FAST FILL MATRIX 1" NOZZLE	P370	RED
N380-1	FAST FILL MATRIX 1" NOZZLE	P380	GOLD

NOZZLE WITH PLUG		
PART NO	DESCRIPTION	PLUG COLOUR
N310P-1	FAST FILL MATRIX 1" NOZZLE WITH PLUG	GREEN
N320P-1	FAST FILL MATRIX 1" NOZZLE WITH PLUG	BLUE
N330P-1	FAST FILL MATRIX 1" NOZZLE WITH PLUG	PURPLE
N340P-1	FAST FILL MATRIX 1" NOZZLE WITH PLUG	GREY
N350P-1	FAST FILL MATRIX 1" NOZZLE WITH PLUG	ORANGE
N360P-1	FAST FILL MATRIX 1" NOZZLE WITH PLUG	YELLOW
N370P-1	FAST FILL MATRIX 1" NOZZLE WITH PLUG	RED
N380P-1	FAST FILL MATRIX 1" NOZZLE WITH PLUG	GOLD

RECEIVER VITON SEALS WITHOUT CAP, SEPARATELY SOLD			
PART NO	DESCRIPTION	PLUG	PLUG COLOUR
R310V-1	FAST FILL MATRIX 1" RECEIVER	C310	GREEN
R320V-1	FAST FILL MATRIX 1" RECEIVER	C320	BLUE
R330V-1	FAST FILL MATRIX 1" RECEIVER	C330	PURPLE
R340V-1	FAST FILL MATRIX 1" RECEIVER	C340	GREY
R350V-1	FAST FILL MATRIX 1" RECEIVER	C350	ORANGE
R360V-1	FAST FILL MATRIX 1" RECEIVER	C360	YELLOW
R370V-1	FAST FILL MATRIX 1" RECEIVER	C370	RED
R380V-1	FAST FILL MATRIX 1" RECEIVER	C380	GOLD

RECEIVER VITON SEALS WITH CAP		
PART NO	DESCRIPTION	PLUG COLOUR
R310VC-1	FAST FILL MATRIX 1" RECEIVER	GREEN
R320VC-1	FAST FILL MATRIX 1" RECEIVER	BLUE
R330VC-1	FAST FILL MATRIX 1" RECEIVER	PURPLE
R340VC-1	FAST FILL MATRIX 1" RECEIVER	GREY
R350VC-1	FAST FILL MATRIX 1" RECEIVER	ORANGE
R360VC-1	FAST FILL MATRIX 1" RECEIVER	YELLOW
R370VC-1	FAST FILL MATRIX 1" RECEIVER	RED
R380VC-1	FAST FILL MATRIX 1" RECEIVER	GOLD

	OPERATING PRESSURE	103 BAR	1500 PSI
THREADS	NOZZLE	1" FNPT	
	RECEIVER	1" MNPT	
MATERIALS	Anodized Aluminium and Nickel plated Steel with Color-coding and keyed to prevent cross-contamination.		

MATRIX NOZZLES & RECEIVERS – OIL & FLUID TRANSFER



FLAT FACE MATRIX 200 SERIES



NOZZLE WITHOUT PLUG, SEPARATELY SOLD			
PART NO	DESCRIPTION	CAP	PLUG COLOUR
FFN210	FLAT-FACE MATRIX 3/4" NOZZLE	NC210	GREEN
FFN220	FLAT-FACE MATRIX 3/4" NOZZLE	NC220	BLUE
FFN230	FLAT-FACE MATRIX 3/4" NOZZLE	NC230	PURPLE
FFN240	FLAT-FACE MATRIX 3/4" NOZZLE	NC240	GREY
FFN245	FLAT-FACE MATRIX 3/4" NOZZLE	NC245	TEAL
FFN250	FLAT-FACE MATRIX 3/4" NOZZLE	NC250	ORANGE
FFN255	FLAT-FACE MATRIX 3/4" NOZZLE	NC255	CLEAR
FFN260	FLAT-FACE MATRIX 3/4" NOZZLE	NC260	YELLOW
FFN265	FLAT-FACE MATRIX 3/4" NOZZLE	NC265	BROWN
FFN270	FLAT-FACE MATRIX 3/4" NOZZLE	NC270	RED
FFN275	FLAT-FACE MATRIX 3/4" NOZZLE	NC275	HOT PINK
FFN280	FLAT-FACE MATRIX 3/4" NOZZLE	NC280	GOLD
FFN285	FLAT-FACE MATRIX 3/4" NOZZLE	NC285	GUN METAL BLUE

RECEIVER WITH 3/4" FEMALE THREAD			
PART NO	DESCRIPTION	CAP	COLOUR CODE
FFR210-34F	FLAT-FACE MATRIX 3/4" NPT FEMALE	C210	GREEN
FFR220-34F	FLAT-FACE MATRIX 3/4" NPT FEMALE	C220	BLUE
FFR230-34F	FLAT-FACE MATRIX 3/4" NPT FEMALE	C230	PURPLE
FFR240-34F	FLAT-FACE MATRIX 3/4" NPT FEMALE	C240	GREY
FFR245-34F	FLAT-FACE MATRIX 3/4" NPT FEMALE	C245	TEAL
FFR250-34F	FLAT-FACE MATRIX 3/4" NPT FEMALE	C250	ORANGE
FFR255-34F	FLAT-FACE MATRIX 3/4" NPT FEMALE	C255	CLEAR
FFR260-34F	FLAT-FACE MATRIX 3/4" NPT FEMALE	C260	YELLOW
FFR265-34F	FLAT-FACE MATRIX 3/4" NPT FEMALE	C265	BROWN
FFR270-34F	FLAT-FACE MATRIX 3/4" NPT FEMALE	C270	RED
FFR275-34F	FLAT-FACE MATRIX 3/4" NPT FEMALE	C275	HOT PINK
FFR280-34F	FLAT-FACE MATRIX 3/4" NPT FEMALE	C280	GOLD
FFR285-34F	FLAT-FACE MATRIX 3/4" NPT FEMALE	C285	GUN METAL BLUE

RECEIVER WITHOUT CAP, SEPARATELY SOLD			
PART NO	DESCRIPTION	CAP	PLUG COLOUR
FFR210	FLAT-FACE MATRIX 3/4" NPT MALE	C210	GREEN
FFR220	FLAT-FACE MATRIX 3/4" NPT MALE	C220	BLUE
FFR230	FLAT-FACE MATRIX 3/4" NPT MALE	C230	PURPLE
FFR240	FLAT-FACE MATRIX 3/4" NPT MALE	C240	GREY
FFR245	FLAT-FACE MATRIX 3/4" NPT MALE	C245	TEAL
FFR250	FLAT-FACE MATRIX 3/4" NPT MALE	C250	ORANGE
FFR255	FLAT-FACE MATRIX 3/4" NPT MALE	C255	CLEAR
FFR260	FLAT-FACE MATRIX 3/4" NPT MALE	C260	YELLOW
FFR265	FLAT-FACE MATRIX 3/4" NPT MALE	C265	BROWN
FFR270	FLAT-FACE MATRIX 3/4" NPT MALE	C270	RED
FFR275	FLAT-FACE MATRIX 3/4" NPT MALE	C275	HOT PINK
FFR280	FLAT-FACE MATRIX 3/4" NPT MALE	C280	GOLD
FFR285	FLAT-FACE MATRIX 3/4" NPT MALE	C285	GUN METAL BLUE

RECEIVER WITH CAP		
PART NO	DESCRIPTION	PLUG COLOUR
FFR210C	FLAT-FACE MATRIX 3/4" NPT MALE WITH CAP	GREEN
FFR220C	FLAT-FACE MATRIX 3/4" NPT MALE WITH CAP	BLUE
FFR230C	FLAT-FACE MATRIX 3/4" NPT MALE WITH CAP	PURPLE
FFR240C	FLAT-FACE MATRIX 3/4" NPT MALE WITH CAP	GREY
FFR245C	FLAT-FACE MATRIX 3/4" NPT MALE WITH CAP	TEAL
FFR250C	FLAT-FACE MATRIX 3/4" NPT MALE WITH CAP	ORANGE
FFR255C	FLAT-FACE MATRIX 3/4" NPT MALE WITH CAP	CLEAR
FFR260C	FLAT-FACE MATRIX 3/4" NPT MALE WITH CAP	YELLOW
FFR265C	FLAT-FACE MATRIX 3/4" NPT MALE WITH CAP	BROWN
FFR270C	FLAT-FACE MATRIX 3/4" NPT MALE WITH CAP	RED
FFR275C	FLAT-FACE MATRIX 3/4" NPT MALE WITH CAP	HOT PINK
FFR280C	FLAT-FACE MATRIX 3/4" NPT MALE WITH CAP	GOLD
FFR285C	FLAT-FACE MATRIX 3/4" NPT MALE WITH CAP	GUN METAL BLUE

The Matrix Flat Face coupling line is the ultimate solution in no-hassle, contaminate-free filling. The "Flat Face" surface on the nozzle allows ease in wiping the dust and dirt from the front end of the nozzle, before coupling, to ensure contaminant-free fluid delivery. The "Flat Face" series includes 13 colour-coded nozzles and receivers designed to physically interlock with only their respective matching colour.

	OPERATING PRESSURE	103 BAR	1500 PSI
THREADS	NOZZLE	3/4" FNPT	
	RECEIVER	3/4" MNPT	
MATERIALS Anodized Aluminium and Nickel plated Steel with Color-coding and keyed to prevent cross-contamination.			

MATRIX NOZZLES & RECEIVERS – OIL & FLUID TRANSFER



MATRIX 34 MX HIGH FLOW SERIES NOZZLES AND RECEIVERS



NOZZLE WITHOUT PLUG, SEPARATELY SOLD			
PART NO	DESCRIPTION	CAP	COLOUR CODE
MXN1-1	MX HIGH FLOW MATRIX 1" NPT	PMX1	RED
MXN2-1	MX HIGH FLOW MATRIX 1" NPT	PMX2	YELLOW
MXN3-1	MX HIGH FLOW MATRIX 1" NPT	PMX3	TEAL
MXN4-1	MX HIGH FLOW MATRIX 1" NPT	PMX4	PURPLE
MXN5-1	MX HIGH FLOW MATRIX 1" NPT	PMX5	BLUE
MXN6-1	MX HIGH FLOW MATRIX 1" NPT	PMX6	COPPER
MXN7-1	MX HIGH FLOW MATRIX 1" NPT	PMX7	GREY

NOZZLE WITH PLUG		
PART NO	DESCRIPTION	COLOUR CODE
MXN1-1P	MX HIGH FLOW MATRIX 1" NPT	RED
MXN2-1P	MX HIGH FLOW MATRIX 1" NPT	YELLOW
MXN3-1P	MX HIGH FLOW MATRIX 1" NPT	TEAL
MXN4-1P	MX HIGH FLOW MATRIX 1" NPT	PURPLE
MXN5-1P	MX HIGH FLOW MATRIX 1" NPT	BLUE
MXN6-1P	MX HIGH FLOW MATRIX 1" NPT	COPPER
MXN7-1P	MX HIGH FLOW MATRIX 1" NPT	GREY

RECEIVER WITHOUT CAP, SEPARATELY SOLD			
PART NO	DESCRIPTION	CAP	COLOUR CODE
MXR1-1	MX HIGH FLOW MATRIX 1" NPT MALE	CMX1	RED
MXR2-1	MX HIGH FLOW MATRIX 1" NPT MALE	CMX2	YELLOW
MXR3-1	MX HIGH FLOW MATRIX 1" NPT MALE	CMX3	TEAL
MXR4-1	MX HIGH FLOW MATRIX 1" NPT MALE	CMX4	PURPLE
MXR5-1	MX HIGH FLOW MATRIX 1" NPT MALE	CMX5	BLUE
MXR6-1	MX HIGH FLOW MATRIX 1" NPT MALE	CMX6	COPPER
MXR7-1	MX HIGH FLOW MATRIX 1" NPT MALE	CMX7	GREY

RECEIVER WITH CAP		
PART NO	DESCRIPTION	COLOUR CODE
MXR1-1C	MX HIGH FLOW MATRIX 1" NPT MALE	RED
MXR2-1C	MX HIGH FLOW MATRIX 1" NPT MALE	YELLOW
MXR3-1C	MX HIGH FLOW MATRIX 1" NPT MALE	TEAL
MXR4-1C	MX HIGH FLOW MATRIX 1" NPT MALE	PURPLE
MXR5-1C	MX HIGH FLOW MATRIX 1" NPT MALE	BLUE
MXR6-1C	MX HIGH FLOW MATRIX 1" NPT MALE	COPPER
MXR7-1C	MX HIGH FLOW MATRIX 1" NPT MALE	GREY

	OPERATING PRESSURE	103 BAR	1500 PSI
THREADS	NOZZLE	1" FNPT	
	RECEIVER	1" MNPT	
MATERIALS	Anodized Aluminium and Nickel plated Steel with Color-coding and keyed to prevent cross-contamination.		

The Matrix 34 MX High Flow Series is part of Fast Fill Systems' Matrix range of quick-connect fluid coupling components designed to prevent cross-contamination between different fluids by using colour-coded, non-interchangeable nozzle/receiver pairs.

Colour-coded nozzle & receiver pairs: Each set is uniquely colour coded so the nozzle will only connect with its matching receiver, preventing fluid mix-ups. Dry-break high-flow design: These are 1" dry-break connectors engineered for higher flow applications such as bulk oil or fluid transfer where spill-free connection and disconnection is critical. Robust construction: Steel bodies with aluminium grips, caps, and plugs for durability and long service life. Use with plugs and caps: Recommended to always use plugs and caps to protect against contamination and damage when the components are not connected.

MATRIX NOZZLES & RECEIVERS – OIL & FLUID TRANSFER



MATRIX EVACUATION TOOLS FOR MATRIX RANGE



Matrix Series Standard evacuation tools ET290 & ET290J

Designed to interlock with all R310V – R380V Matrix Standard Series Receivers for “evacuation purposes”

The ET290 3/4” NPT female thread.

The ET290J 125 1 1/4” NPT female thread. The ET290J 1-5/16”-16 JIC male hose connection



Matrix Series Flat-face evacuation tool FFET290

Designed to inter-lock with all flat face matrix receivers for evacuation purposes.

FFET290 3/4” NPT female thread

FFET290-J
1 5/16”-16 JIC Male hose connection



Matrix Series MX High Flow evacuation tool MXET-1

Designed to accommodate all the MX Matrix receivers and has an integrated internal check-valve to allow fluid evacuation only.

MXET-1 1” NPT female thread

STANDARD COUPLERS **CRANKCASE**

Designed for transferring the primary fluids used on heavy equipment. Nozzle and receiver pairs only connect with their corresponding size and colour.

R100C
CRANKCASE RECEIVER & CAP



R100JC *
CRANKCASE RECEIVER & CAP



R100RC #
"R SERIES" CRANKCASE RECEIVER & CAP



N100P
CRANKCASE NOZZLE & PLUG
PIN LATCHING



N100UP
CRANKCASE NOZZLE WITH PLUG,
BALL LATCH, 3/4"



N100RP #
"R SERIES" CRANKCASE NOZZLE WITH
PLUG, BALL LATCH, 3/4"



STANDARD
OPERATING PRESSURE

34.5 BAR
500 PSI

BURST
PRESSURE
103.4 BAR
1500 PSI

FLOW
AREA
.305 SQ "
7.74954
mm

NOZZLE
THREAD
3/4" MNPT
19.05 mm

RECEIVER THREAD
3/4" MNPT
19.05 mm

R SERIES
OPERATING PRESSURE

34.5 BAR
500 PSI

BURST
PRESSURE
103.4 BAR
1500 PSI

FLOW
AREA
.364 SQ "
9.2456 mm

NOZZLE
THREAD
3/4" FNPT
19.05 mm

RECEIVER THREAD
OD 1-5/8" 12 TPI ID 1-
5/16"
41mm OD, 34 mm ID

*JIC bases on these receivers have extended JIC threads that can be fitted into a bulkhead; a female JIC hose can then be attached on the other side of the bulkhead.

R Series used for remote bulkhead mounting for common fluids. The receiver's dual threads are designed to allow bulk-head mounting using the male thread and connection of a hose to a leak-free female ORB thread. Note: R series couplers DO NOT connect with Standard couplers.

STANDARD COUPLERS COOLANT



Designed for transferring the primary fluids used on heavy equipment. Nozzle and receiver pairs only connect with their corresponding size and colour.

R200C
COOLANT RECEIVER & CAP



R200JC *
COOLANT RECEIVER & CAP



R200RC #
"R SERIES" COOLANT RECEIVER & CAP



N200P
COOLANT NOZZLE & PLUG PIN
LATCHING



N200UP
COOLANT NOZZLE WITH PLUG,
BALL LATCH, 3/4"



N200RP #
"R SERIES" COOLANT NOZZLE WITH
PLUG, BALL LATCH, 3/4"



STANDARD

OPERATING PRESSURE	BURST PRESSURE	FLOW AREA	NOZZLE THREAD	RECEIVER THREAD
34.5 BAR	103.4 BAR	.112 SQ "	1/2" MNPT	1/2" MNPT
500 PSI	1500 PSI	2.8448 mm	12.7 mm	12.7 mm

R SERIES

OPERATING PRESSURE	BURST PRESSURE	FLOW AREA	NOZZLE THREAD	RECEIVER THREAD
34.5 BAR	103.4 BAR	.136 SQ "	1/2" FNPT	OD 1-3/16" 12 TPI ID 7/8" 14 TPI (-10 ORB)
500 PSI	1500 PSI	3.4544 mm	12.7 mm	30.16 mm OD, 22.25 mm ID

*JIC bases on these receivers have extended JIC threads that can be fitted into a bulkhead; a female JIC hose can then be attached on the other side of the bulkhead. # R Series used for remote bulkhead mounting for common fluids. The receiver's dual threads are designed to allow bulk-head mounting using the male thread and connection of a hose to the leak-free female ORB thread. Note: R series couplers DO NOT connect with Standard couplers.

STANDARD COUPLERS HYDRAULIC



Designed for transferring the primary fluids used on heavy equipment. Nozzle and receiver pairs only connect with their corresponding size and colour.

R300C
HYDRAULIC RECEIVER & CAP



R300JC *
HYDRAULIC RECEIVER & CAP



R300RC #
"R SERIES" HYDRAULIC RECEIVER & CAP



N300P
HYDRAULIC NOZZLE & PLUG
PIN LATCHING



N300BP
HYDRAULIC NOZZLE WITH
PLUG, BALL LATCH, 3/4"



N300RP #
"R SERIES" HYDRAULIC NOZZLE
WITH PLUG, BALL LATCH, 3/4"



STANDARD

OPERATING PRESSURE	BURST PRESSURE	FLOW AREA	NOZZLE THREAD	RECEIVER THREAD
34.5 BAR	103.4 BAR	.2212 SQ "	3/4" MNPT	3/4" MNPT
500 PSI	1500 PSI	5.61848 mm [N300BP	19.05 mm	19.05 mm

R SERIES

OPERATING PRESSURE	BURST PRESSURE	FLOW AREA	NOZZLE THREAD	RECEIVER THREAD
34.5 BAR	103.4 BAR	.421 SQ "	1" FNPT	OD 1-7/8" 12 TPI ID 1-5/8" 12 TPI
500 PSI	1500 PSI	10.6934 mm	25.4 mm	47.625 mm OD, 41.275 mm ID

*JIC bases on these receivers have extended JIC threads that can be fitted into a bulkhead; a female JIC hose can then be attached on the other side of the bulkhead.

R Series used for remote bulkhead mounting for common fluids. The receiver's dual threads are designed to allow bulk-head mounting using the male thread and connection of a hose to the leak-free female ORB thread. Note: R series couplers DO NOT connect with Standard couplers.

STANDARD COUPLERS TRANSMISSION

Designed for transferring the primary fluids used on heavy equipment. Nozzle and receiver pairs only connect with their corresponding size and colour.

R400C
TRANSMISSION RECEIVER &
CAP



R400JC *
TRANSMISSION RECEIVER &
CAP



R400RC #
"R SERIES" TRANSMISSION
RECEIVER &
CAP



N400P
TRANSMISSION NOZZLE &
PLUG PIN LATCHING



N400RP #
"R SERIES"
TRANSMISSION NOZZLE WITH
PLUG, BALL LATCH, 3/4"



**STANDARD
OPERATING
PRESSURE**
34.5 BAR
500 PSI

**BURST
PRESSURE**
103.4 BAR
1500 PSI

FLOW AREA
.1136 SQ "
2.88544 mm

**NOZZLE
THREAD**
1/2" MNPT
12.7 mm

RECEIVER THREAD
1/2" MNPT
12.7 mm

**R SERIES
OPERATING
PRESSURE**
34.5 BAR
500 PSI

**BURST
PRESSURE**
103.4 BAR
1500 PSI

FLOW AREA
.229 SQ "
5.8166 mm

**NOZZLE
THREAD**
3/4" FNPT
19.05 mm

RECEIVER THREAD
OD 1-5/16" 12 TPI ID 1-
1/16"
33.33mm OD, 26.98mm
ID

*JIC bases on these receivers have extended JIC threads that can be fitted into a bulkhead; a female JIC hose can then be attached on the other side of the bulkhead.

R Series used for remote bulkhead mounting for common fluids. The receiver's dual threads are designed to allow bulk-head mounting using the male thread and connection of a hose to the leak-free female ORB thread. Note: R series couplers DO NOT connect with Standard couplers.

STANDARD COUPLERS - COLOURED RANGE (FLOMAX X OVER)

Designed for transferring the primary fluids used on heavy equipment. Nozzle and receiver pairs only connect with their corresponding size and colour.



N100P, CRANKCASE NOZZLE WITH PLUG (UNIVERSAL) (RED), MATCHES FLOMAX ENBL-P



N102P, NOZZLE WITH PLUG, BALL LATCH, 3/4" MNPT (GOLD), MATCHES FLOMAX ENBL-P2



N103P, NOZZLE WITH PLUG, BALL LATCH, 3/4" MNPT (TEAL), MATCHES FLOMAX ENBL-P3



R100C, RECEIVER WITH CAP 3/4" MNPT (RED POPPET), MATCHES FLOMAX ERS-C



R102C, RECEIVER WITH CAP, 3/4" MNPT (GOLD POPPET), MATCHES FLOMAX ERS-C2



R103C, RECEIVER WITH CAP, 3/4" MNPT (TEAL POPPET), MATCHES FLOMAX ERS-C3



N104P, NOZZLE WITH PLUG, BALL LATCH, 3/4" MNPT (VIOLET), MATCHES FLOMAX ENBL-C4



N105P, NOZZLE WITH PLUG, BALL LATCH, 3/4" MNPT (BLUE), MATCHES FLOMAX ENBL-P5



N106P, NOZZLE WITH PLUG, BALL LATCH, 3/4" MNPT (COPPER), MATCHES FLOMAX ENBL-P6



R104C, RECEIVER WITH CAP, 3/4" MNPT (VIOLET POPPET), MATCHES FLOMAX ERS-C4



R105C, RECEIVER WITH CAP, 3/4" MNPT (BLUE POPPET), MATCHES FLOMAX ERS-C5



R106C, RECEIVER WITH CAP, 3/4" MNPT (COPPER POPPET), MATCHES FLOMAX ERS-C6

STANDARD				
OPERATING PRESSURE	BURST PRESSURE	FLOW AREA	NOZZLE THREAD	RECEIVER THREAD
34.5 BAR	103.4 BAR	.2212 SQ "	3/4" MNPT	3/4" MNPT
500 PSI	1500 PSI	5.61848 mm [N300BP	19.05 mm	19.05 mm
		7.74954 mm]		

Standard Couplers

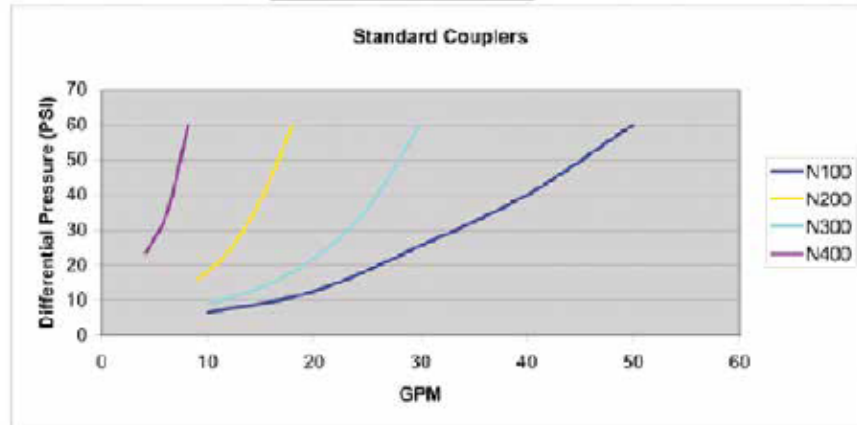

Flow chart shown as a sample curve. Actual flow and pressures will vary depending on fluid used.

N100

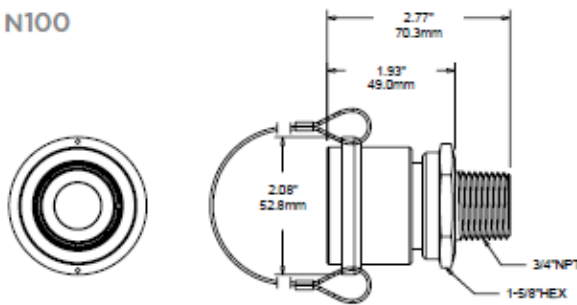

N100U

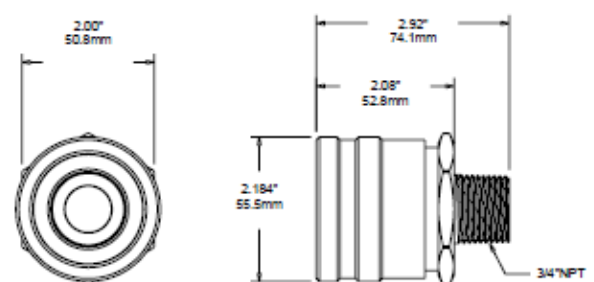

P100

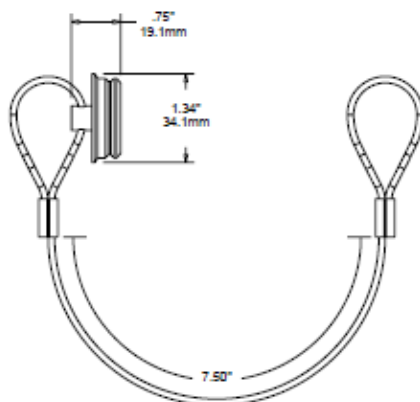

R100

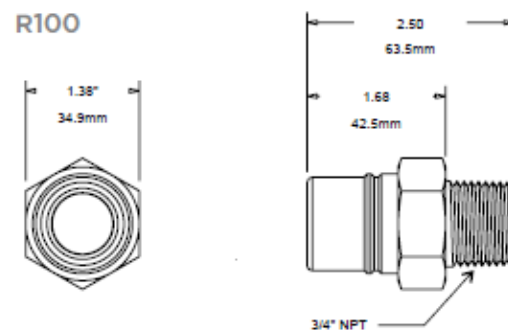

R100J

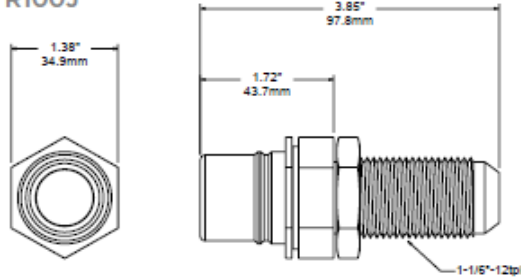

C100

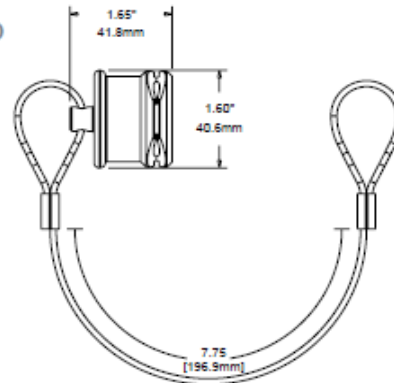

N200

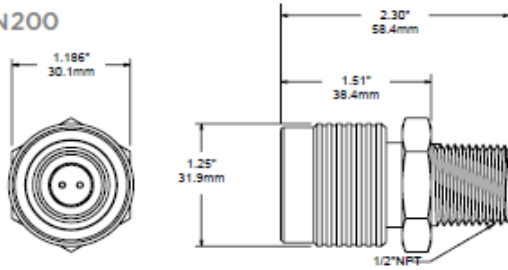

N200 12

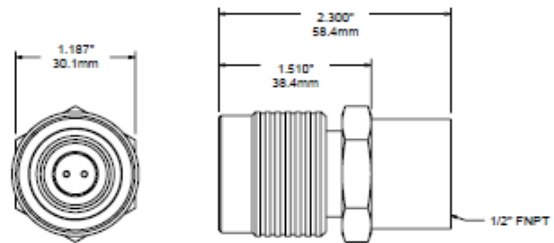

N200 34

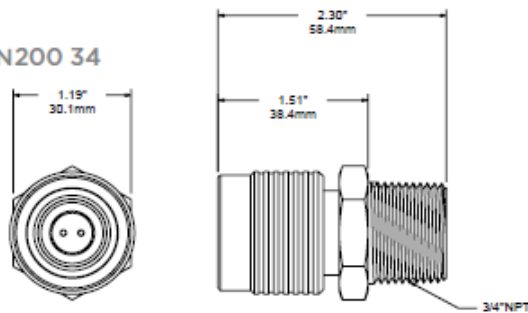

P200

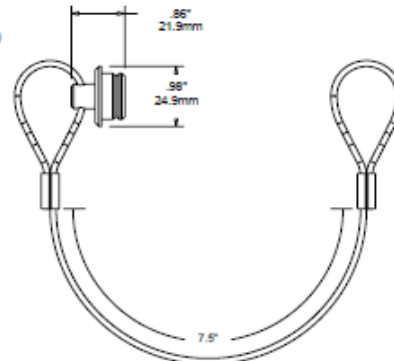

R200

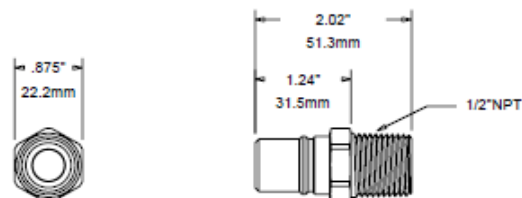

R200J

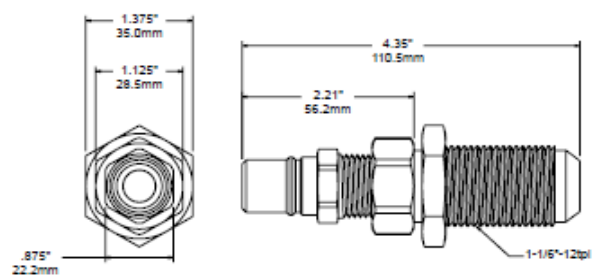

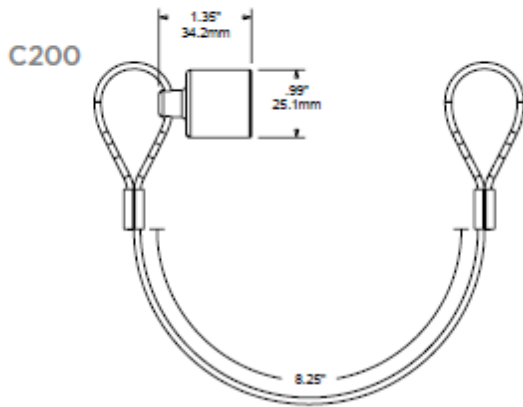

N300 (DOG)

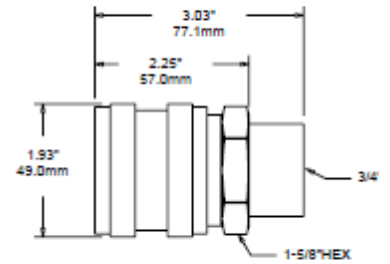

N300B

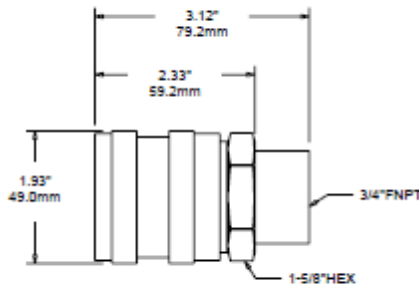

N300 34

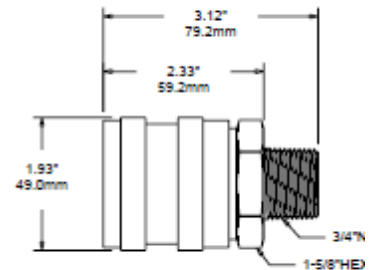

P300

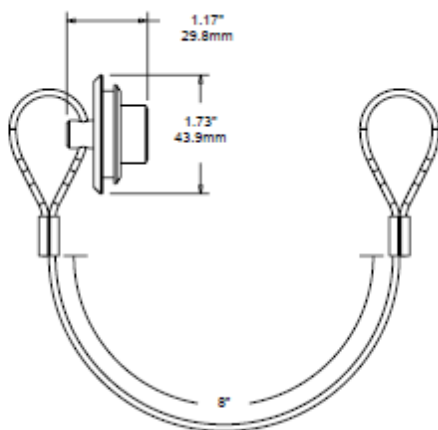

R300

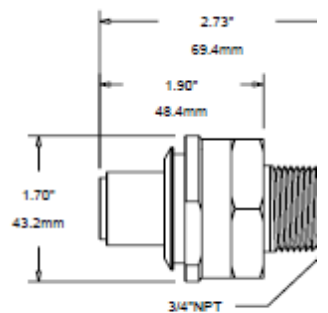
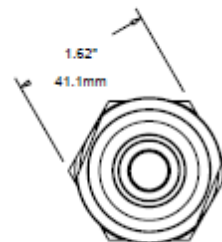

R300J

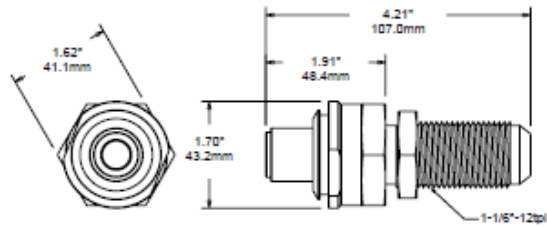

C300

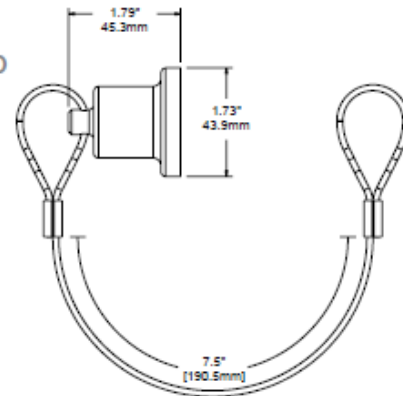

N400

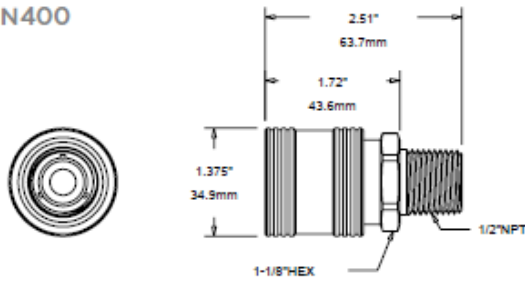

N400 34

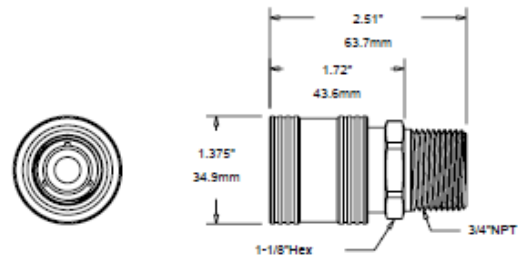

N400 38

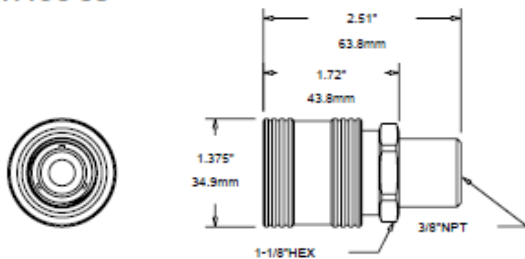

P400

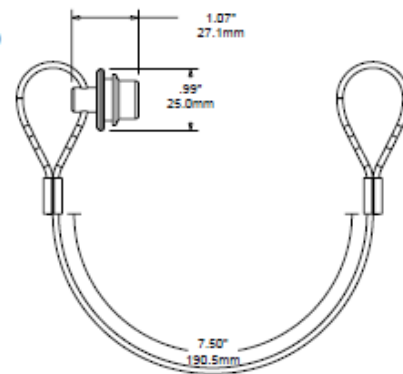

R400

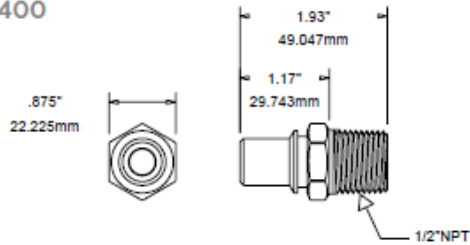

R400J

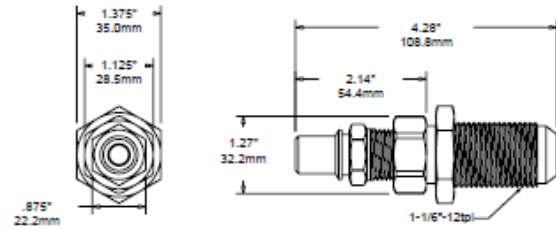

R400 34

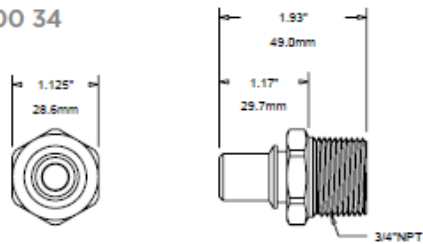

R400 38

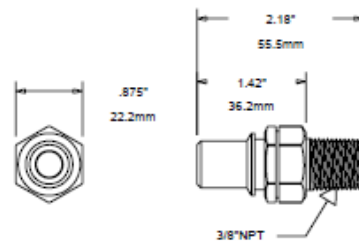

C400

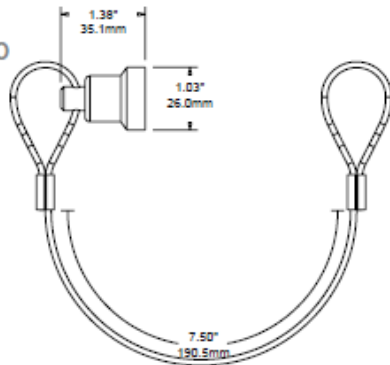

"R" Series Couplers

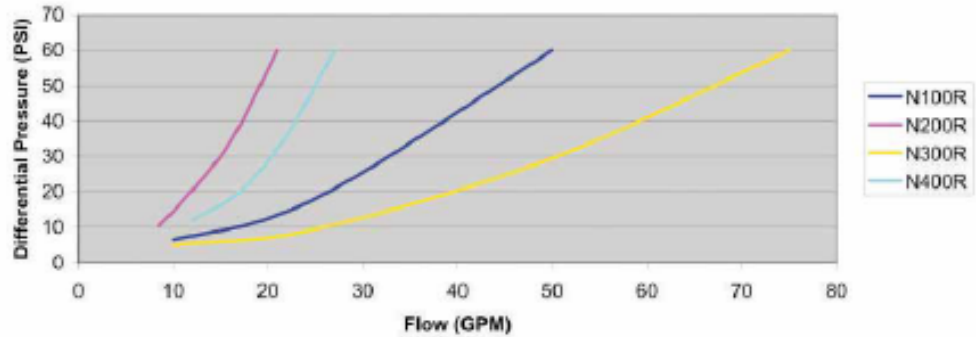

Flow chart shown as a sample curve. Actual flow and pressures will vary depending on fluid used. Chart data for Viscor 1487 Calibration Fluid at 72° F

N100R

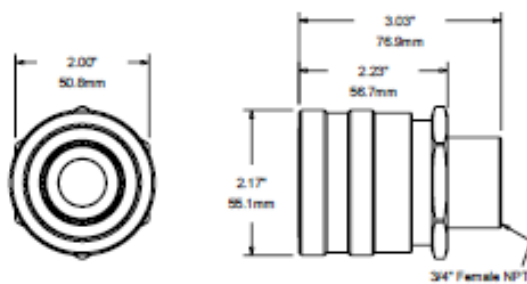

N100U

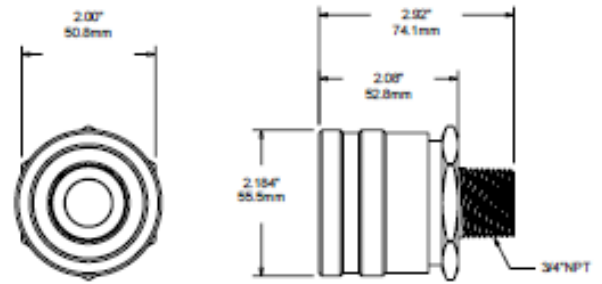

P100R

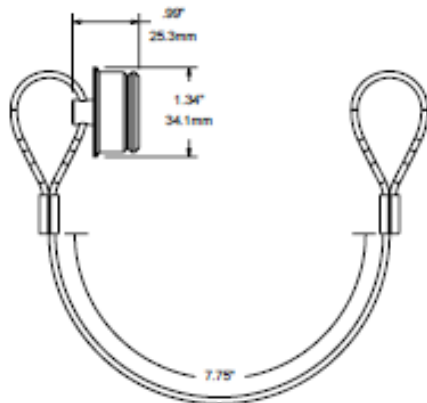

P100

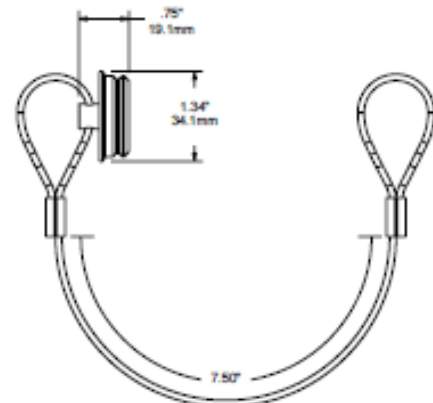

R100R

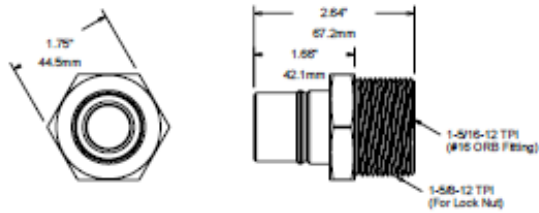

C100R

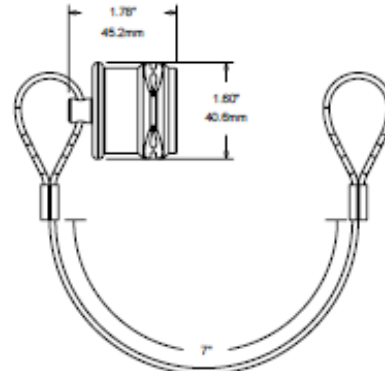

N200R

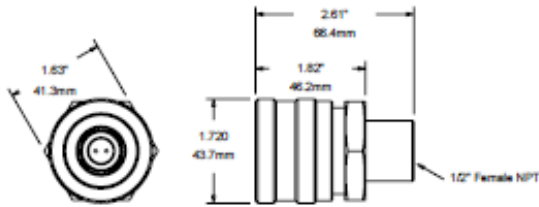

P200R

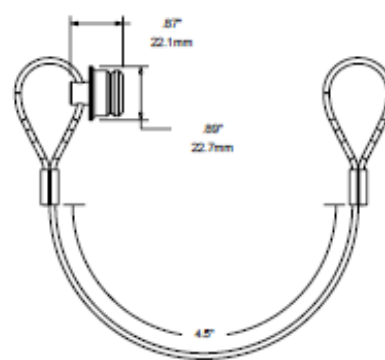

R200R

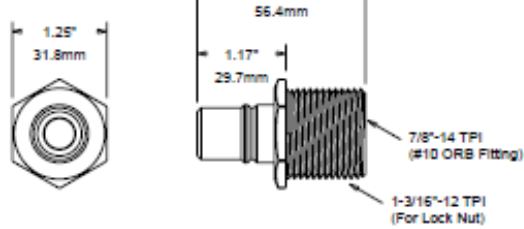

C200R

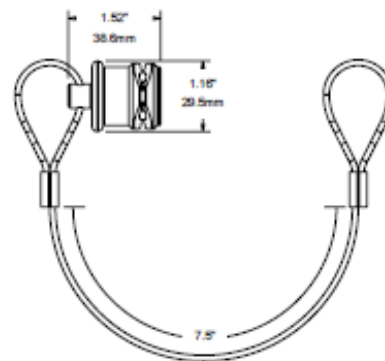

N300R



P300R

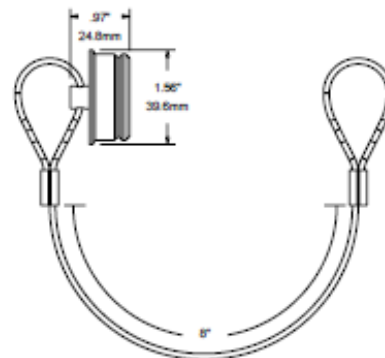

R300R

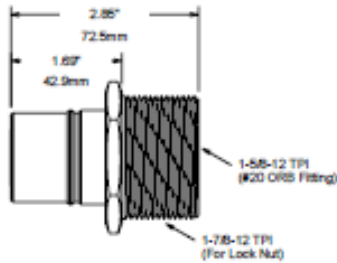

C300R

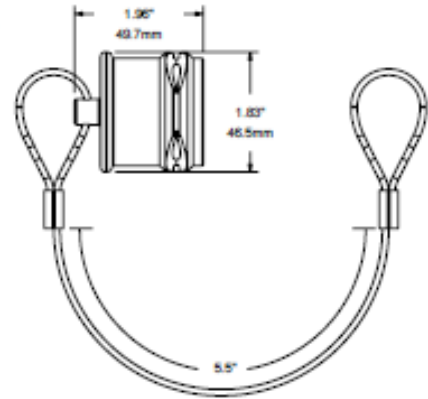

N400R

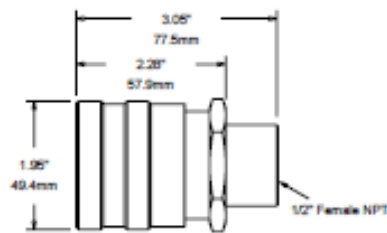

P400R

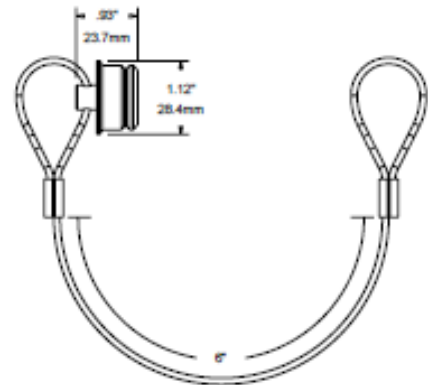

R400R

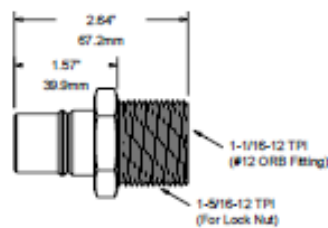
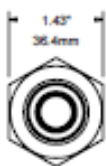

C400R

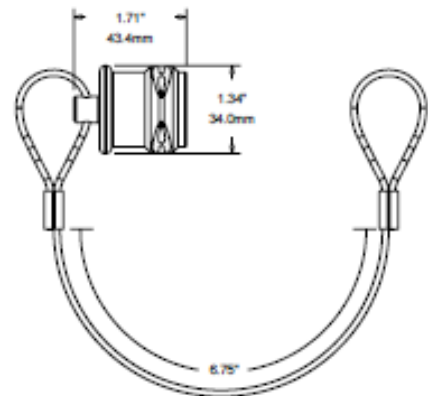



Matrix 34 Flow Test

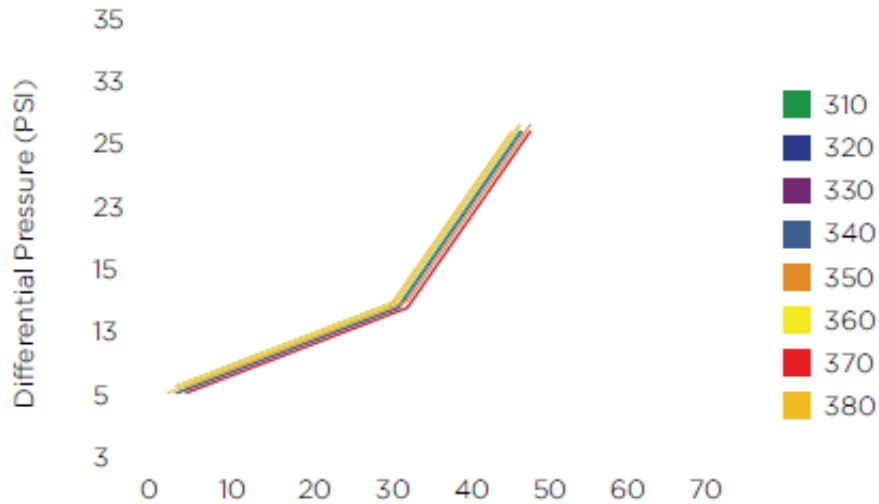

Fluid used for test: Mineral or White Spirits
 SG @ 68F: 0.79
 Viscosity @ 68F: 0.74 cp
 Temp of fluid during test: 71.1 F

Differential Pressure (PSI)

FLOW (GPM)	310	320	330	340	350	360	370	380
6.5	4	4	3	3	3	3	3	3
20	7	7	6.5	6.5	6.5	7	7	7
30	12	12	10.5	10.5	11.5	11.5	11	11
45	24	24	23	23	23	23	23	23

**Specifications true across the whole series of Matrix couplers

Operating Pressures	1500 PSI
Burst Pressures	4500 PSI
Operating Temperatures	-10°F to 350°F
Construction	Anodized Aluminum & Nickle Plated Steel

A slimmed down version of our Matrix series of dry-break nozzle. The Matrix 200 nozzles are a direct cross-over from the Matrix 34 and mate with the corresponding color-coded Matrix 34 receiver. They offer the same cross contamination protection in a slimmed down, lighter version.

Operating Pressure

- All Couplers: 1500 PSI

Thread Size

- All Nozzles: 3/4" Female NPT (Standard)

Burst Pressure

- All Couplers: 4500 PSI

Operating Temperature

- All Couplers: -35° F to 250° F

Flow Area

- All Couplers: Approx. .4400 SQ IN

R310 - R380

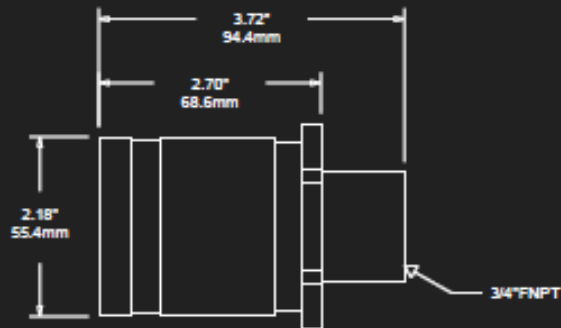
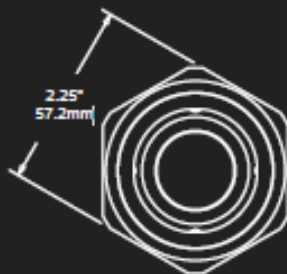

The ET290 is a universal evacuation solution for the matrix dry-break coupler line. It has been designed to accommodate all Matrix receivers and has an integrated internal check valve to allow fluid evacuation only.

The EPK390 has been designed to fit all fluid evacuation ports on Komatsu equipment with the exception of the WA800 and WA900 transmission ports.

Operating Pressure

- All Couplers: 1500 PSI

Burst Pressure

- All Couplers: 4500 PSI

Flow Area

- All Couplers: Approx. .4400 SQ IN

Thread Size

- ET290: 3/4" Female NPT
- ET290J: 16 JIC
- EPK390: M24 1.5mm Pitch

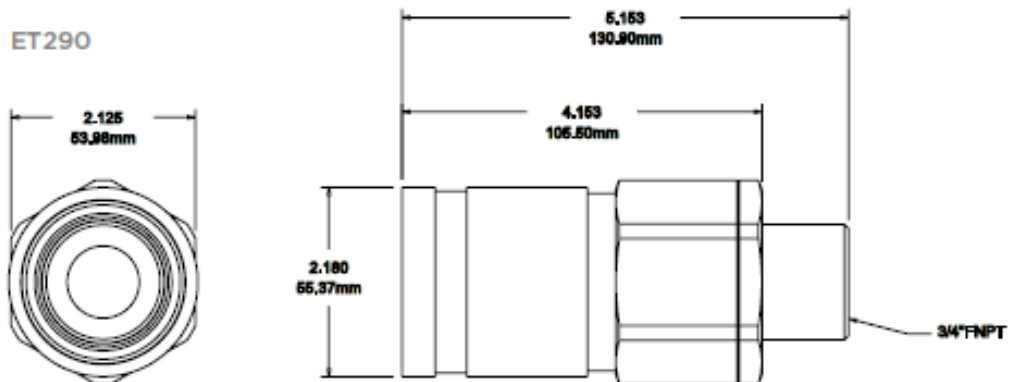

ET290J

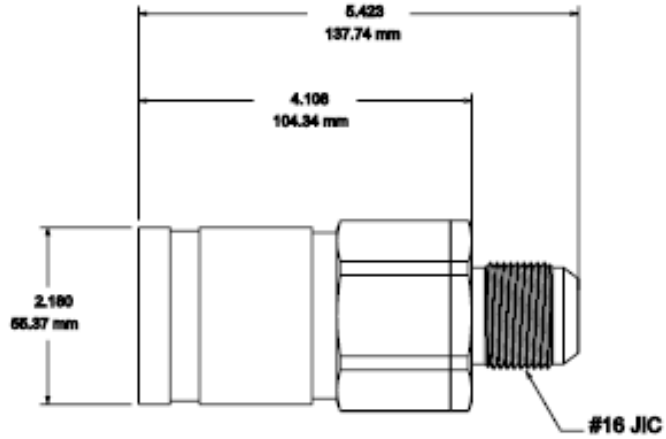
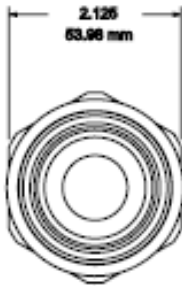

EPK390

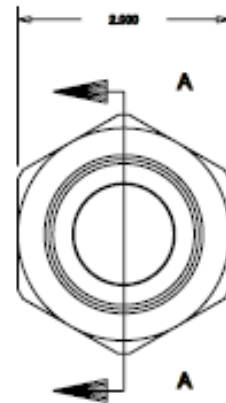
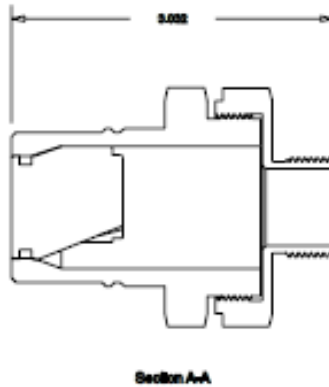
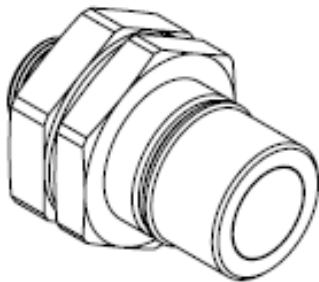

Matrix Receiver (R310-1)

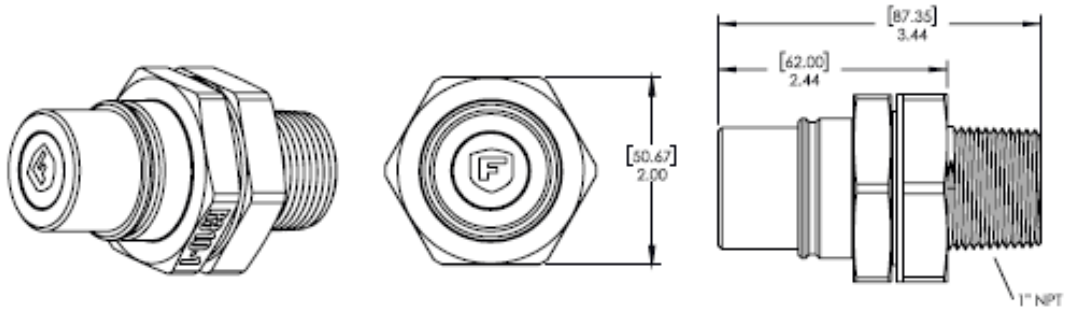

Matrix Receiver (R310-1)

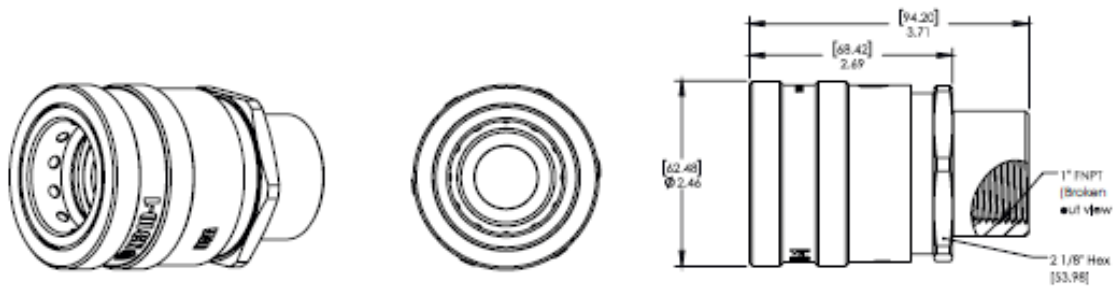

PRESSURELESS APPLICATIONS

Other applications also available, contact us and a design can be arranged.

DIRECT MOUNT RECEIVER

System includes:

A 1 PLA150-M VLCE

Vent/Level Control
Assembly for Internal or
External Signal Line

B 1 PLA150-M SV

Pressureless Inlet/Shut-
off Valve Assembly

C 1 R150CVRc-J

2pc Steel Fuel Receiver
w/cap and green poppet

D 1 pl-p-6

10' Stainless Steel Signal
Line w/ #6 JIC Female
ends

E 1 FFV150-PL

3 Micron Filter Vent
Assembly for Pressureless

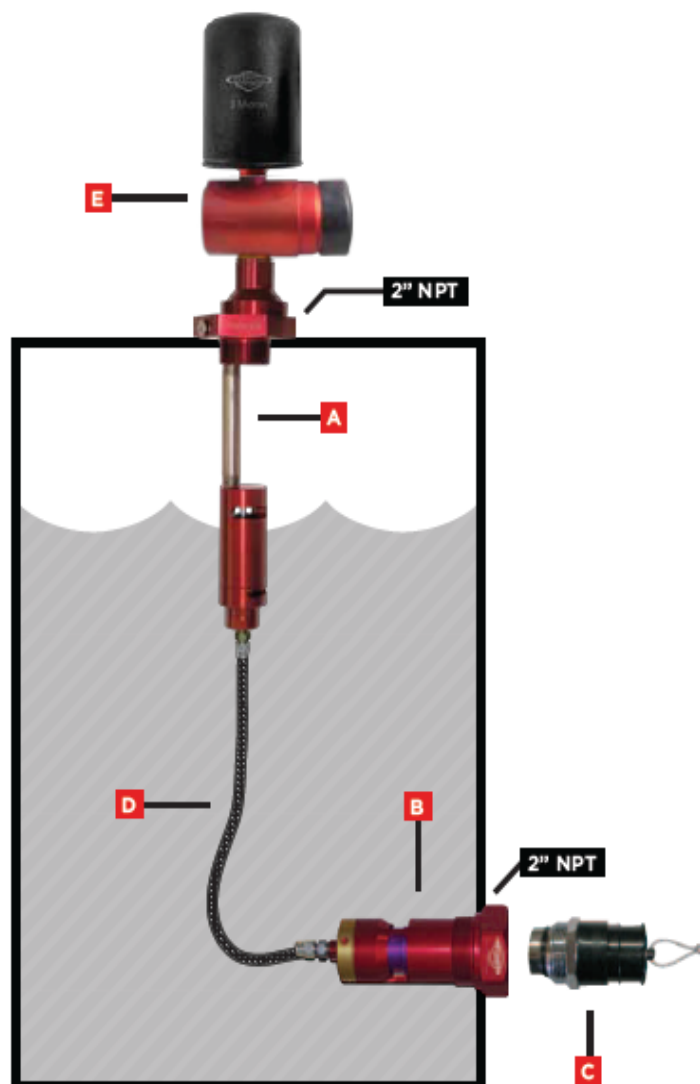

PRESSURELESS APPLICATIONS

Other applications also available, contact us and a design can be arranged.

WORKS WITH BUT NOT LIMITED TO

24M CAT® Grader, 651, 657
Scrapers, 425L

System includes:

A 1 PLA150-M VLCE

Vent/Level Control
Assembly for Internal or
External Signal Line

B 1 PLA150-M SV61

6 Bolt Flange w/
Pressureless Shutoff Valve
w/Code 61 Flange for
Internal Signal Line
Connections

C 1 PLA150-M VF

6 Bolt CAT® Vent Flange
for 2" NPT (Replaces
CAT® 221-5303)

D 1 pl-p-6

10' Stainless Steel Signal
Line w/ #6 JIC Female
ends

E 1 R150Sc-J

Steel Fuel Receiver w/cap
and green poppet

F 1 FFV150-PL

3 Micron Filter Vent
Assembly for Pressureless

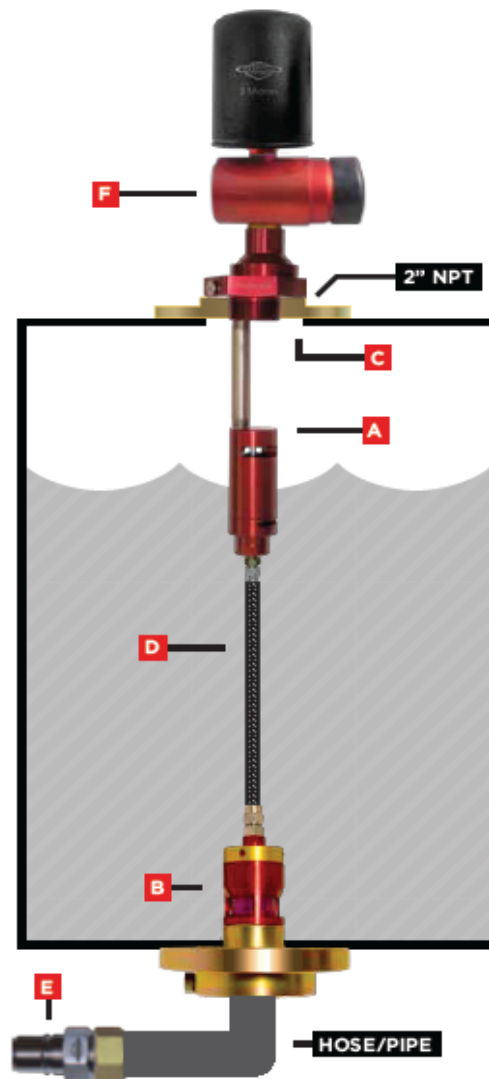

PRESSURELESS APPLICATIONS

Other applications also available, contact us and a design can be arranged.

PLASTIC TANK

System includes:

A 1 PLA150-M VLCE

Vent/Level Control Assembly for Internal or External Signal Line

B 2 PLA150-M PTF

Plastic Fuel tank Flange for either Vent or Receiver - Provides 2" NPT

C 1 PLA150-M SV-1

Pressureless Top Fill Drop-Down Shutoff Valve Assembly w/1ea 12" Tube - Does not include receiver

D 1 R150Sc-J

Steel Fuel Receiver w/ cap and green poppet

E 1 pl-p-6x

Stainless Steel Signal Line w/ #6 JIC Female ends (length to be determined by placement)

F 1 FFV150-PL

3 Micron Filter Vent Assembly for Pressureless

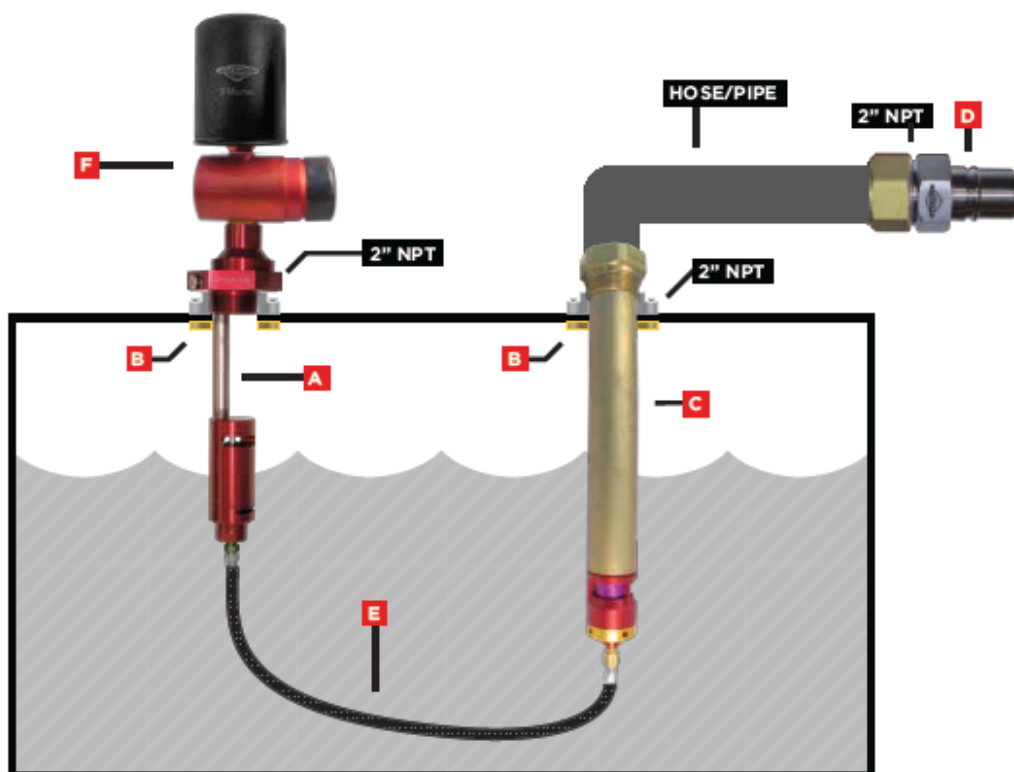

PRESSURELESS APPLICATIONS

Other applications also available, contact us and a design can be arranged.

RH340B TEREX D & K SHOVEL

System Includes:

A 2 PLA150-M VLCE

Vent/Level Control Assembly for Internal or External Signal Line

B 2 PLA150-M RRM-2

Shutoff Valve Mounting "Can" for External Signal Line

D 2 pl-p-6

10' Stainless Steel Signal Line w/ #6 JIC Female ends

C 1 R150Sc-J

1pc Steel Fuel Receiver w/Cap and Green Poppet

E 2 FFV150-PL

3 Micron Filter Vent Assembly for Pressureless

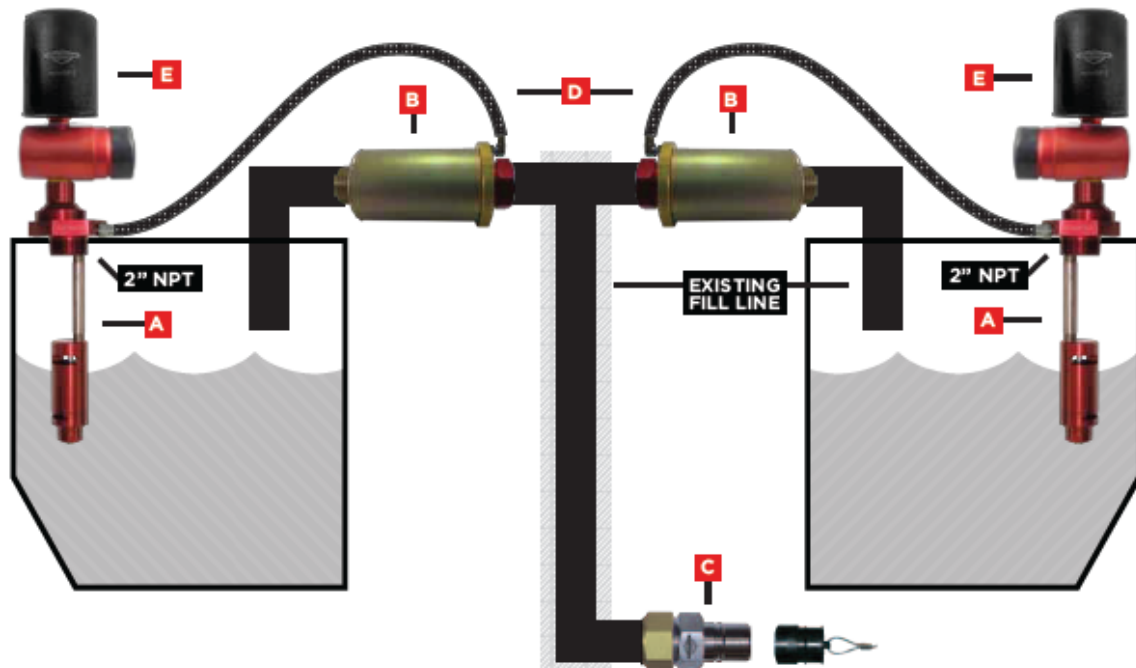

PRESSURELESS APPLICATIONS

Other applications also available, contact us and a design can be arranged.

16M CAT® GRADER

System Includes:

A 1 PLA150-M VLCE

Vent/Level Control Assembly for Internal or External Signal Line

B 1 PLA150-M SV61-12

12 Bolt Flange w/ Pressureless Shutoff Valve Assembly w/ Ext./Int. Signal Line Connections Includes 2 Pc Receiver

C 1 PLA150-M VF

6 Bolt CAT® Vent Flange for 2" NPT (Replaces CAT® 221-5303)

D 1 pl-p-6

10' Stainless Steel Signal Line w/ #6 JIC Female ends

E 1 R150Sc-J

1pc Steel Fuel Receiver w/ Green Poppet

F 1 FFV150-PL

3 Micron Filter Vent Assembly for Pressureless

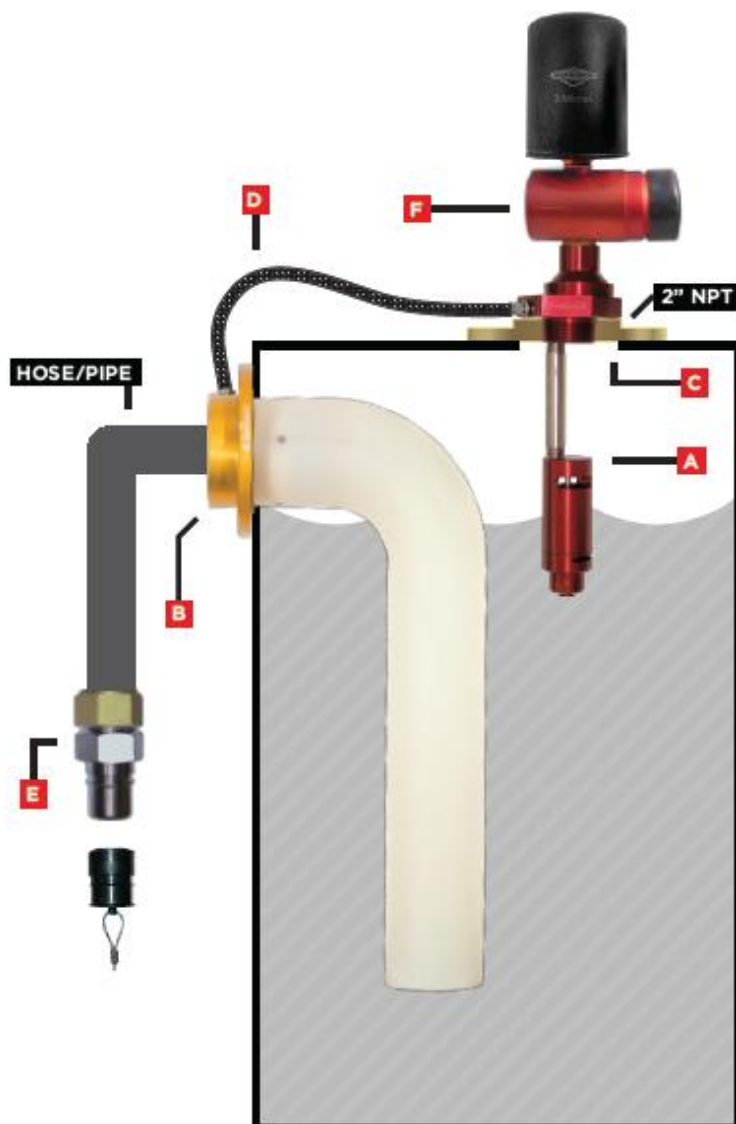

PRESSURELESS APPLICATIONS

Other applications also available, contact us and a design can be arranged.

D7-D11 CAT® DOZERS EXCEPT "R" MODELS

System Includes:

A 1 PLA150-M VLCE-F2

Vent/Level Control Assembly for Internal or External Signal Line

B 1 PLA150-M SV61

6 Bolt Flange w/ Pressureless Shutoff Valve Assembly w/ Int. Signal Line Connections

D 1 pl-p-6

10' Stainless Steel Signal Line w/ #6 JIC Female ends

E 1 R150Sc-J

1pc Steel Fuel Receiver w/ Green Poppet

F 1 FFV150-PL

3 Micron Filter Vent Assembly for Pressureless

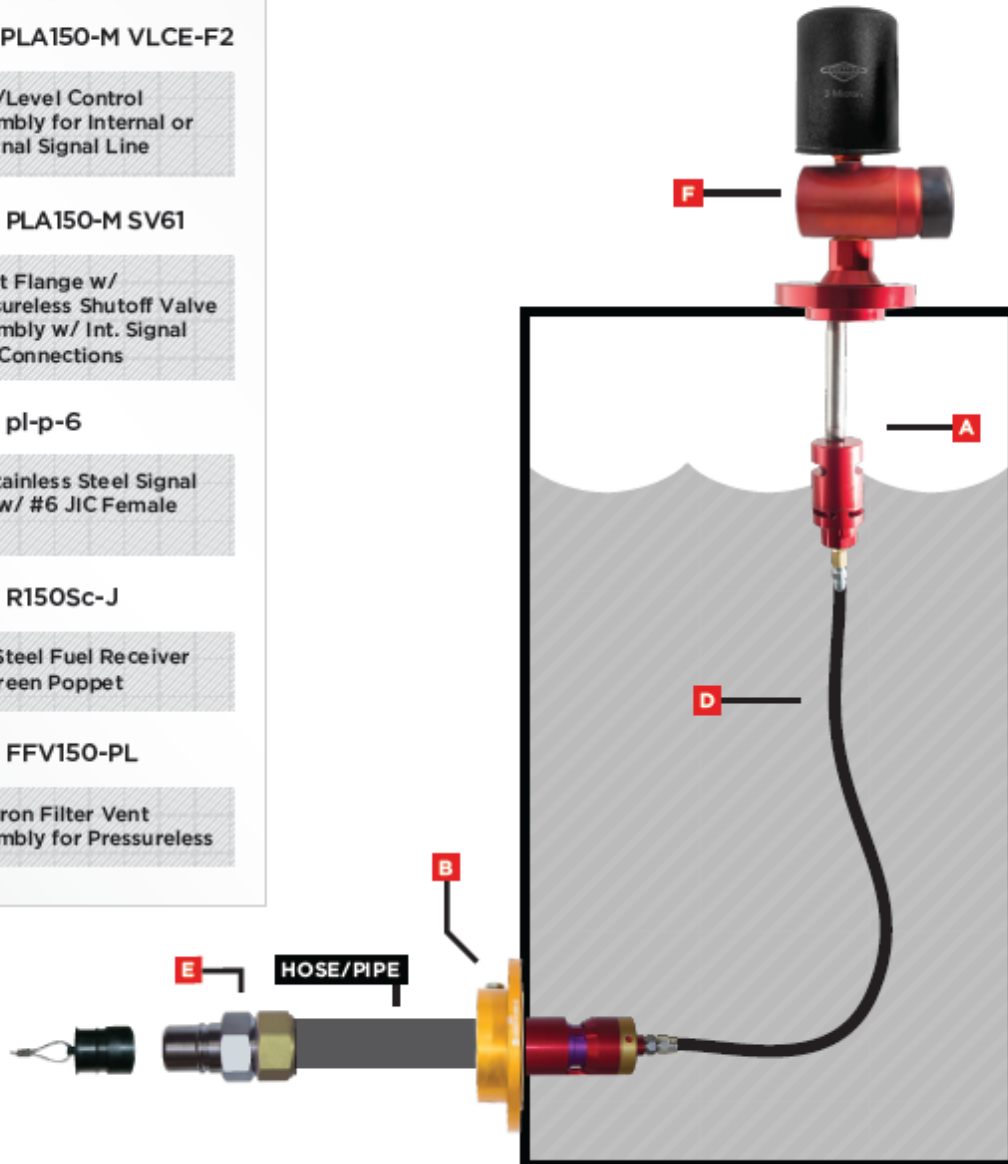

PRESSURELESS APPLICATIONS

Other applications also available, contact us and a design can be arranged.

16M CAT® GRADER CAT® CONFIGURATION

WORKS WITH BUT NOT LIMITED TO 627H CAT® SCRAPER

System Includes:

A 1 PLA150-M VLCE-F2

Vent/Level Control Assembly for Internal or External Signal Line

B 1 PLA150-M SV61-12

12 Bolt Flange w/ Pressureless Shutoff Valve Assembly w/ Int. Signal Line Connections

D 1 pl-p-6

10' Stainless Steel Signal Line w/ #6 JIC Female ends

E 1 R150Sc-J

1pc Steel Fuel Receiver w/ Green Poppet

F 1 FFV150-PL

3 Micron Filter Vent Assembly for Pressureless

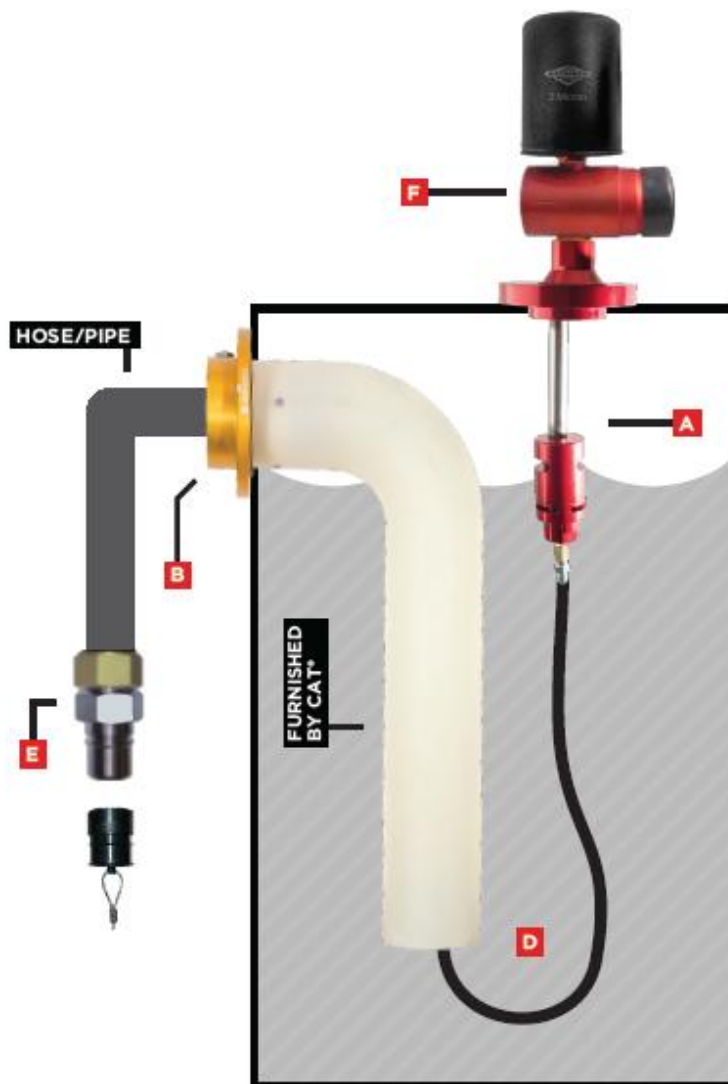

PRESSURELESS APPLICATIONS

Other applications also available, contact us and a design can be arranged.

CAT® 992G WHEEL LOADER

System includes:

- A** 1 PLA150-M VLCE

Vent/Level Control Assembly for Internal or External Signal Line

- B** 2 FFV150-LP

Low Profile 3 Micron Filter Vent Assembly for Pressureless

- C** 1 PLA150-M SV

Pressureless Inlet/Shut-Off Valve Assembly

- D** 1 R150CVRc-J

2pc Steel Fuel Receiver w/cap and green poppet

- E** 1 pl-p-6

10' Stainless Steel Signal Line w/ #6 JIC Female ends

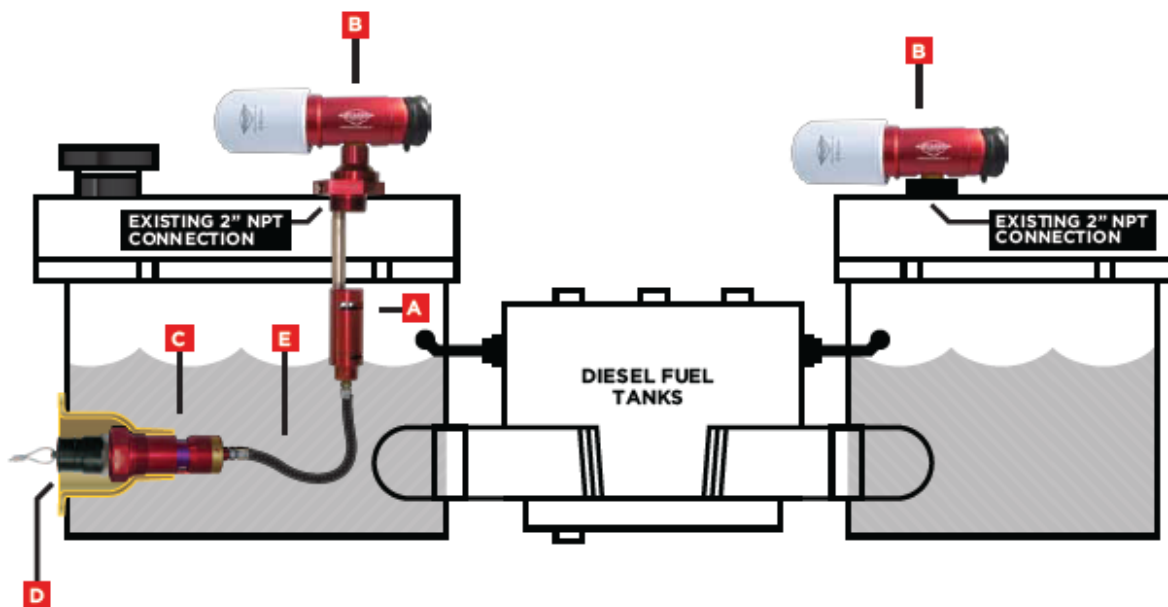

PRESSURELESS APPLICATIONS

Other applications also available, contact us and a design can be arranged.

VOLVO® PRESSURELESS PLATE

WORKS WITH BUT NOT LIMITED TO
A35F, A40F Articulated Dump Truck

PLA150-M VOLVO System Includes:

A 1 PLA150-M VLCE

Vent/Level Control Assembly for Internal or External Signal Line

B 1 PLA-SE-7

Volvo plate Gasket

C 1 PLA150-M SV-2V

2ea 12" Dropdown Tubes w/ Shutoff Valve Assy

D 1 R150Sc-J

2" Steel Fuel Receiver w/ cap and green poppet

E 1 pl-p-6-B

3' Stainless Steel Signal Line w/ #6 JIC Female ends

F 1 PLA-MW-45ABC

Volvo plate w/ Fuel Receiver Neck

G 1 FFV150 LP

Low Profile 3 Micron Filter Vent for Pressureless

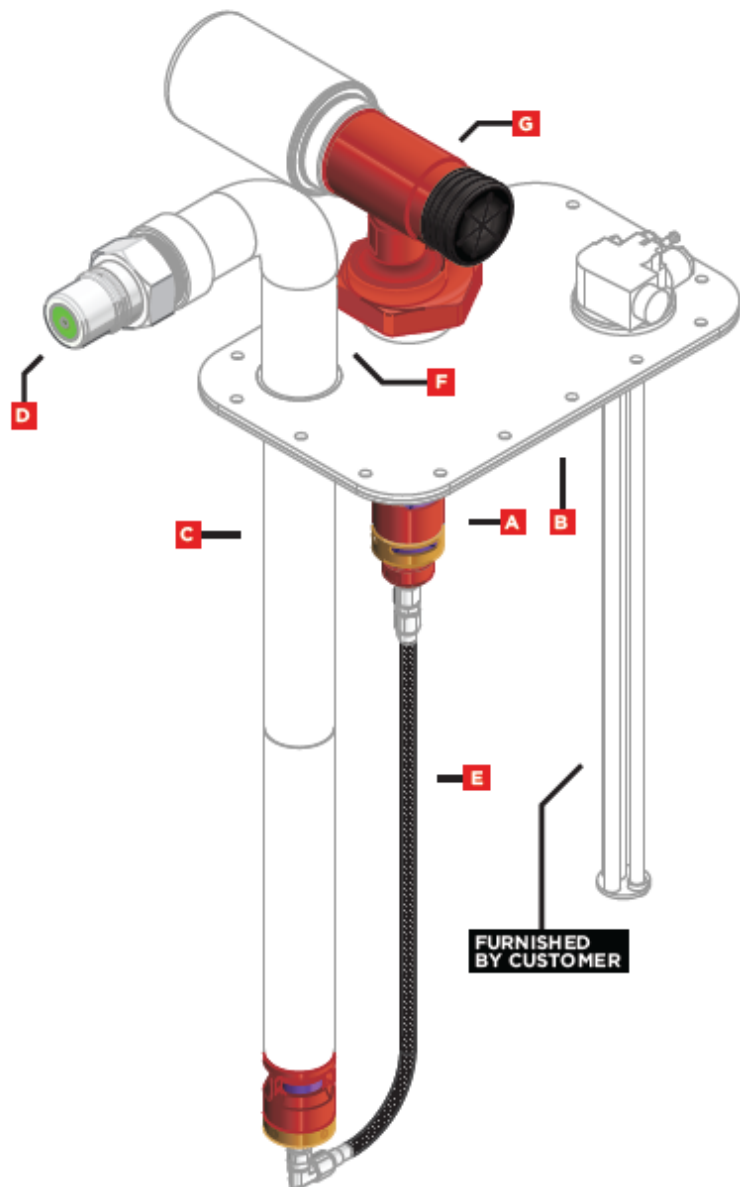

PRESSURELESS APPLICATIONS

Other applications also available, contact us and a design can be arranged.

LIEBHERR T282C HAUL TRUCK

System includes:

A 1 PLA150-M VLCE

Vent/Level Control Assembly for Internal or External Signal Line

B 1 PLA150-M SV

Pressureless Inlet/Shutoff Valve Assembly

C 1 R150CVRc-J

2 pc Steel Fuel Receiver w/Cap and Green Poppet

C 1 PLA-P-38

2" M NPT to 1" F NPT Bushing

D 1 pl-p-6

10' Stainless Steel Signal Line w/ #6 JIC Female ends

E 2 FFV150-PL

3 Micron Filter Vent Assembly for Pressureless

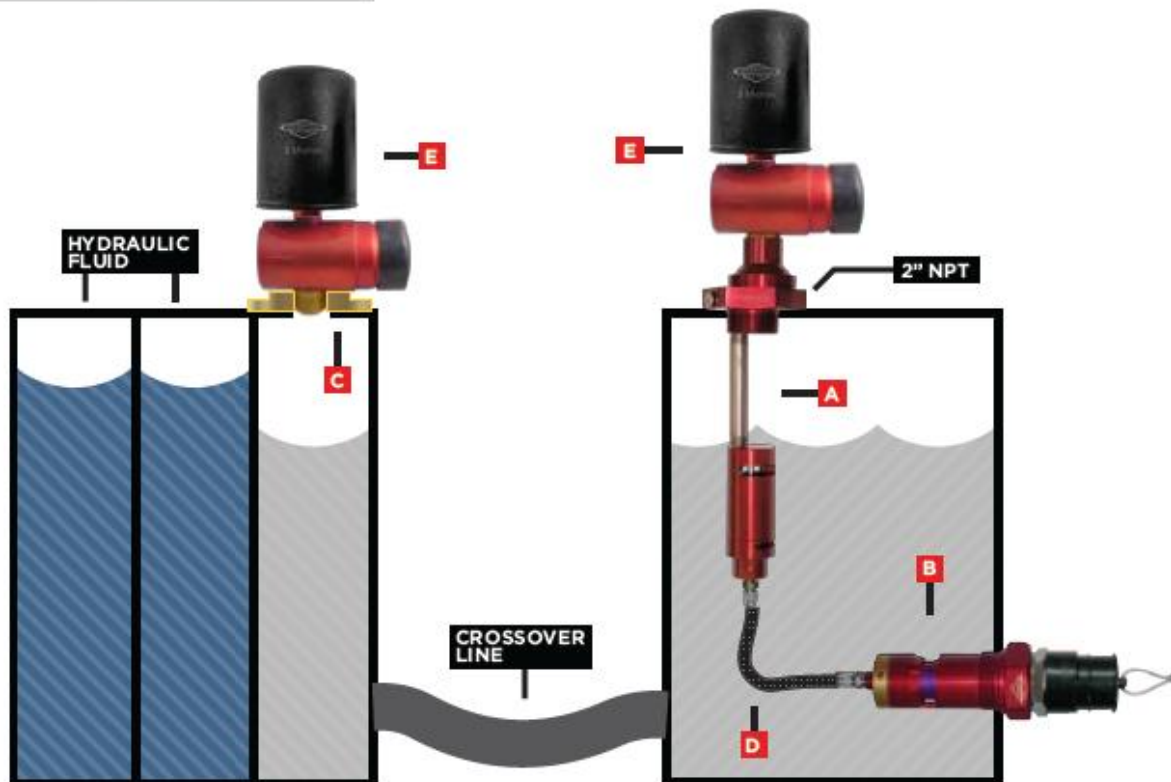

PRESSURELESS APPLICATIONS

Other applications also available, contact us and a design can be arranged.

DIRECT MOUNT WITH BELL HOUSING

System Includes:

A 1 PLA150-M VLCE

Vent/Level Control Assembly for Internal or External Signal Line

B 1 PLA150-M SV

Pressureless Inlet/ Shut-off Valve Assembly

C 1 FFF4C

Flush Mount Weld-On Bell Housing

D 1 pl-p-6

10' Stainless Steel Signal Line w/ #6 JIC Female ends

E 1 FFV150-PL

3 micron Filter Vent Assy for Pressureless

F 1 R150CVRc-J

2pc Steel Fuel Receiver w/ Cap and Green Poppet

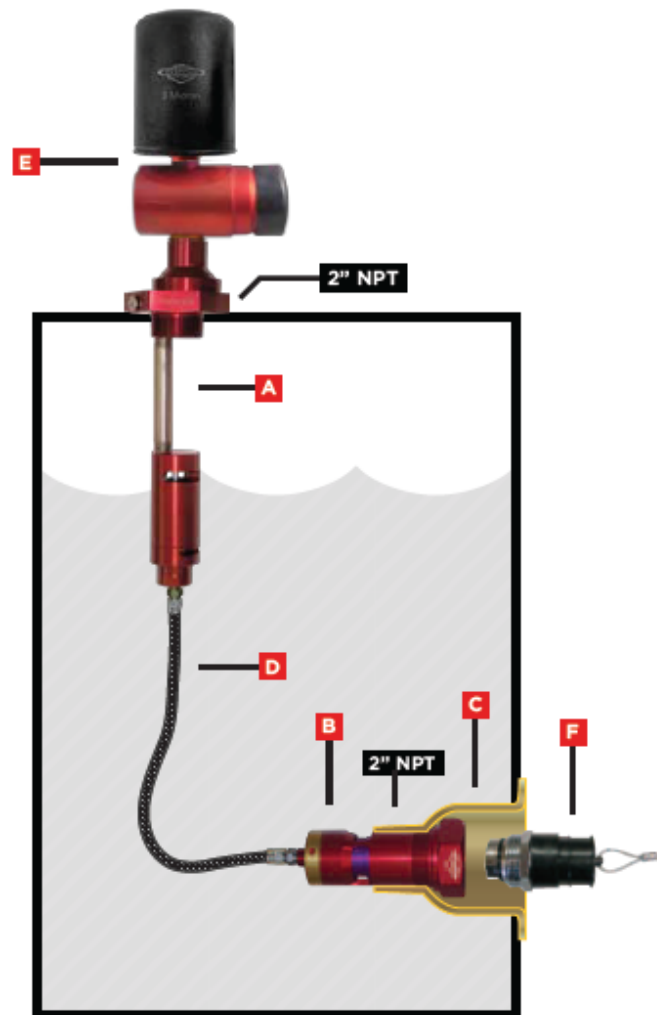

PRESSURELESS APPLICATIONS

Other applications also available, contact us and a design can be arranged.

EXTERNAL SIGNAL LINE FOR BELL HOUSING

System includes:

A 1 PLA150-M VLCE

Vent/Level Control Assembly for Internal or External Signal Line

B 1 PLA150-M SVEBH

Bolt-On Bell Housing Replacement w/Shutoff Valve Assy w/External Signal Line Connection (Includes 2 Pc Receiver)

C 1 FF6C

Weld-On Adapter for Bolt-On Bell Housing Bolt Pattern

D 1 pl-p-6

10' Stainless Steel Signal Line w/ #6 JIC Female ends

E 1 FFV150-PL

3 micron Filter Vent Assy for Pressureless

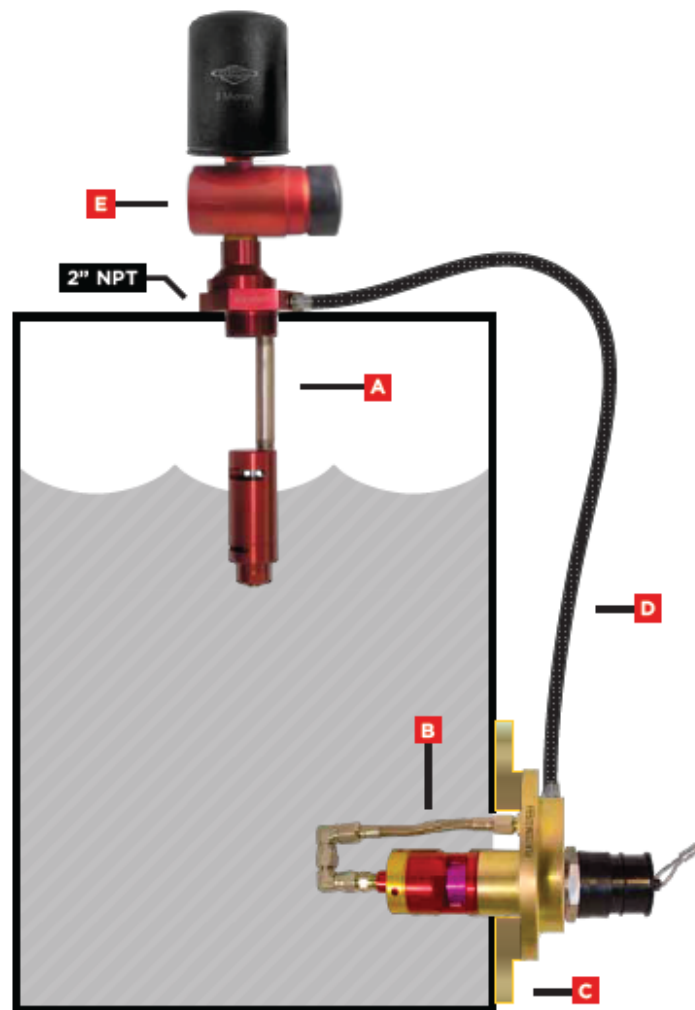

PRESSURELESS APPLICATIONS

Other applications also available, contact us and a design can be arranged.

WORKS WITH BUT NOT LIMITED TO

330, 345, 365, 385 Excavators, 730, 740B CAT® AD Trucks, 980H, 988H, 990H, and 994F Loaders

System includes:

A 1 PLA150-M VLCE

Vent/Level Control Assembly for Internal or External Signal Line

B 1 PLA150-M SVF

6 Bolt Flange w/ Pressureless Shutoff Valve Assy w/ Ext./Int. Signal Line Connections Includes 2 Pc Receiver

C 1 PLA150-M VF

6 Bolt CAT® Vent Flange for 2" NPT (Replaces CAT® # 221-5303)

D 1 pl-p-6

10' Stainless Steel Signal Line w/ #6 JIC Female ends

E 1 FFV150-PL

3 micron Filter Vent Assy for Pressureless

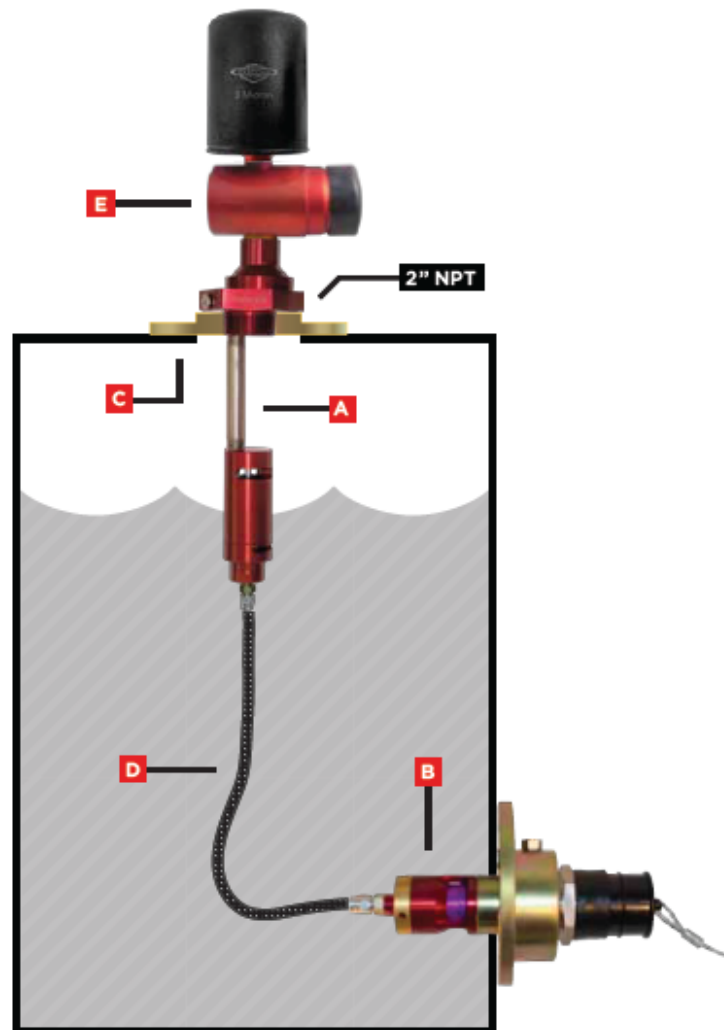



FUEL & OIL TRANSFER | AUTO LUBE | SINGLE POINT LUBRICATORS | FIRE SUPPRESSION | WORKSHOP EQUIPMENT PAGE 60



Authorised Distributor

Australia, Southeast Asia, & Pacific Region

Contact Us: sales@silverieng.com

Australia 1300 766 413

International +61 3 9427 2117

www.silverieng.com



Silveri Engineering & Trading Pty Ltd

sales@silverieng.com | www.silverieng.com | 1300 766 413 | +61 3 9427 2117